

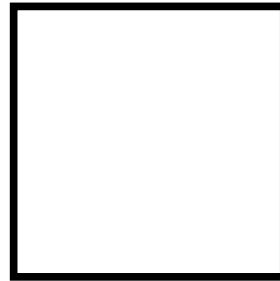

# Wimbledon AX3/5 BLOCK DIAGRAM

PCB STACK UP  
6L

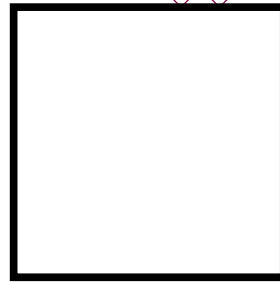

RTL8103EL

PAGE 29

 <b>NBS</b>	<b>PROJECT :AX3</b> Quanta Computer Inc.	
	Size Custom	Document Number <b>Block Diagram</b>
Date: Friday, January 29, 2010		Sheet 1 of 30

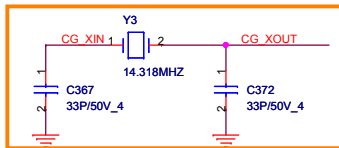
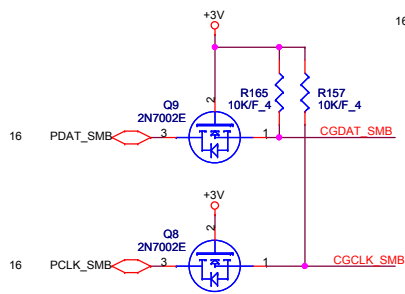
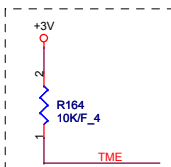
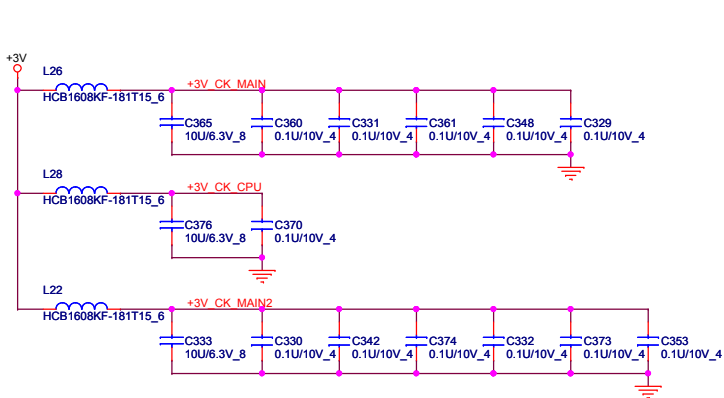

DB:Change from 27P to 33P (TXC suggestion)

0=overclocking of CPU and SRC Allowed  
1 = overclocking of CPU and SRC not Allowed

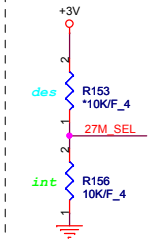

0=UMA  
1 = External VGA

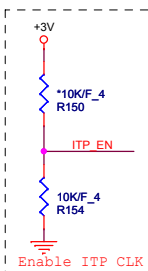

Enable ITP CLK

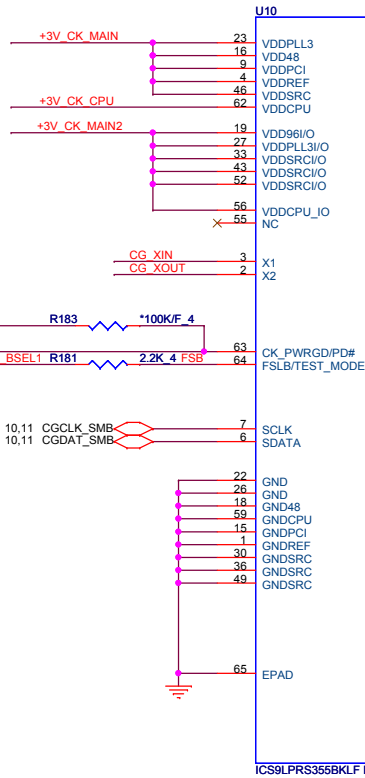

CK505

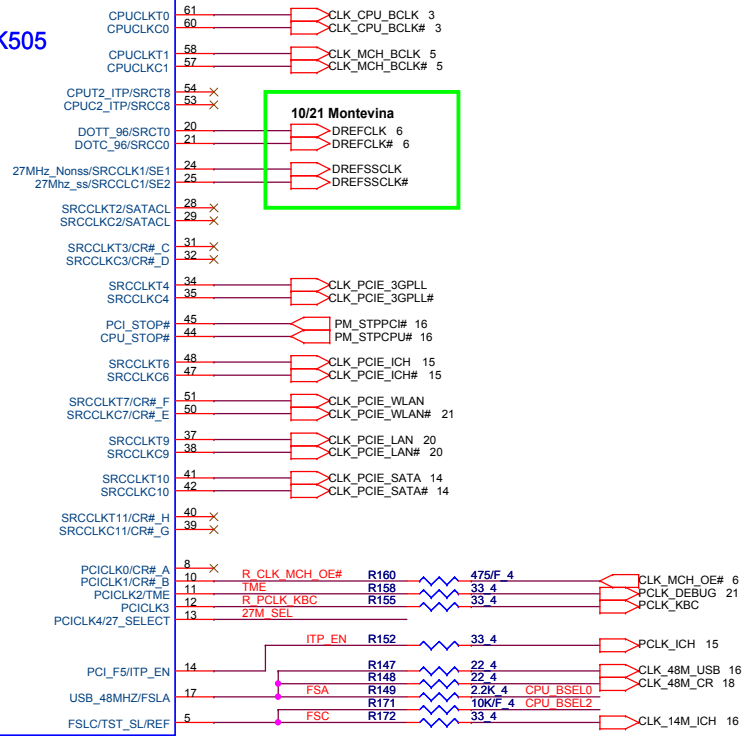

CK505 QFN64

Silego SLG8SP513VTR AL8SP513000  
Realtek RTM875N-606-VD-GR AL000875000  
ICS ICS9LPRS355BKLF ALPRS355000



27M_SEL PIN13	PIN20	PIN21	PIN24	PIN25
0=UMA	DOT96T	DOT96C	SRCT1/LCDT_100	SRCT1/LCDT_100
1 = External VGA	SRCT0	SRCC0	27Mout-NSS	27Mout-SS

CPU Clock select

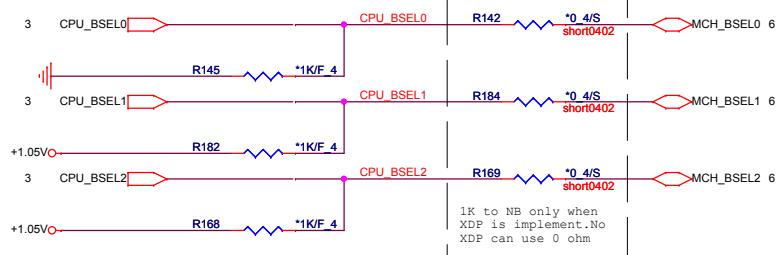

1K to NB only when XDP is implement.No XDP can use 0 ohm

FSC	FSB	FSA	CPU	SRC	PCI
1	0	1	100	100	33
0	0	1	133	100	33
0	1	1	166	100	33
0	1	0	200	100	33
1	0	0	333	100	33
1	1	0	400	100	33
1	1	1	RSVD	100	33

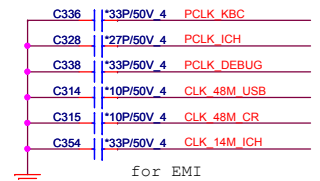

for EMI

**PROJECT :AX3**  
Quanta Computer Inc.

**NBS** Size Custom Document Number **Clock Generator** Rev 2A

Date: Tuesday, February 23, 2010 Sheet 2 of 30



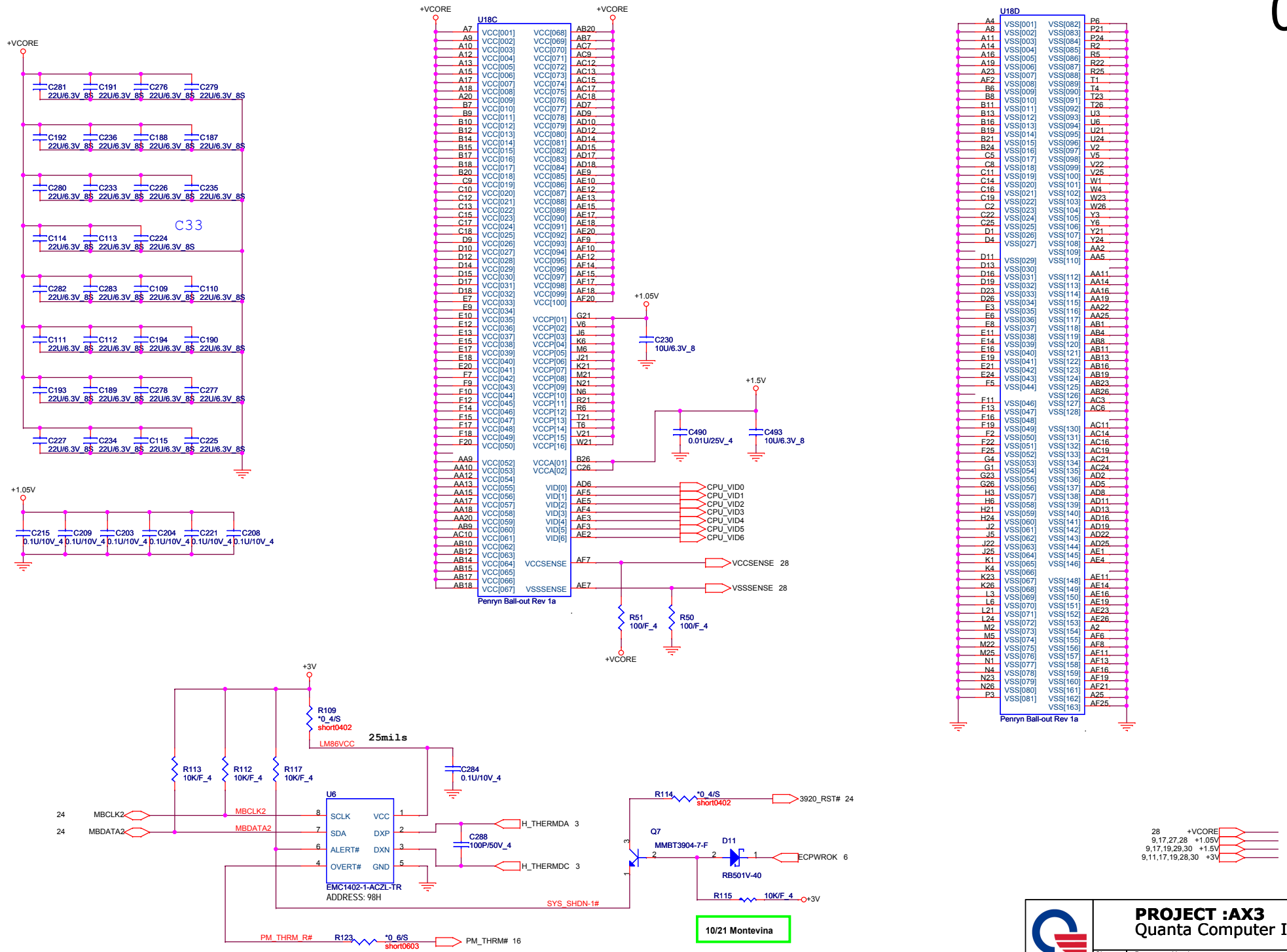

**PROJECT :AX3**  
**Quanta Computer Inc.**

Size Custom Document Number  
**Penryn & TH Monitor 2/2** Rev 2A

**NB5** Date: Tuesday, February 23, 2010 Sheet 4 of 30

10/21 Montevina

28 +VCCORE  
 9,17,27,28 +1.05V  
 9,17,19,29,30 +1.5V  
 9,11,17,19,28,30 +3V





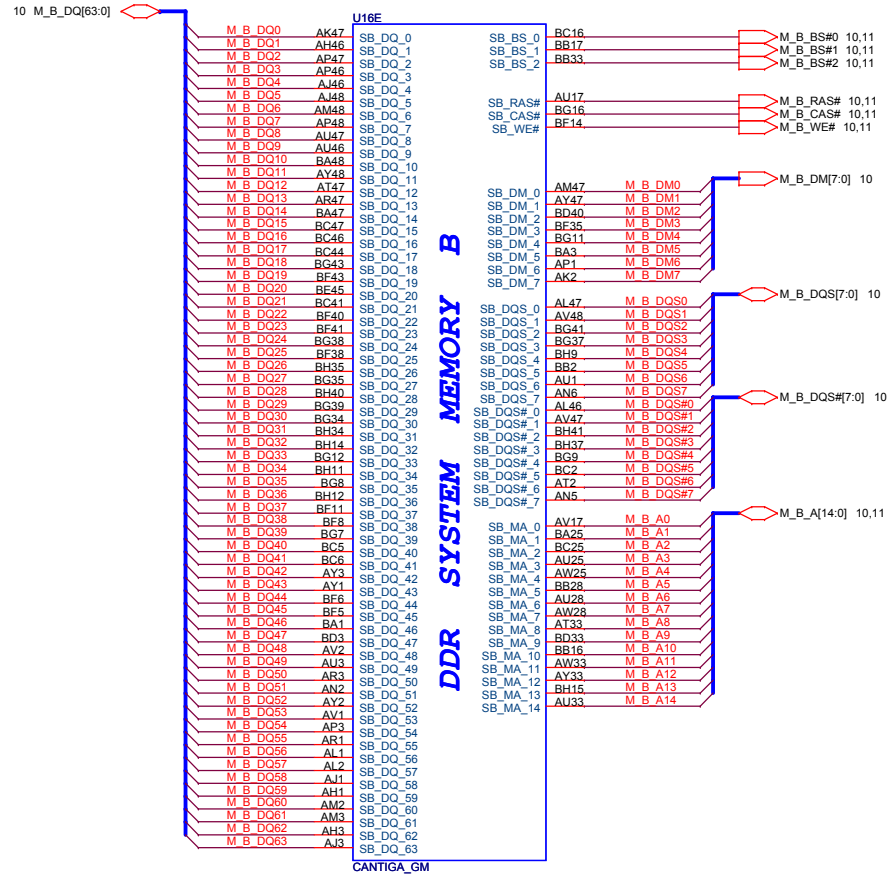
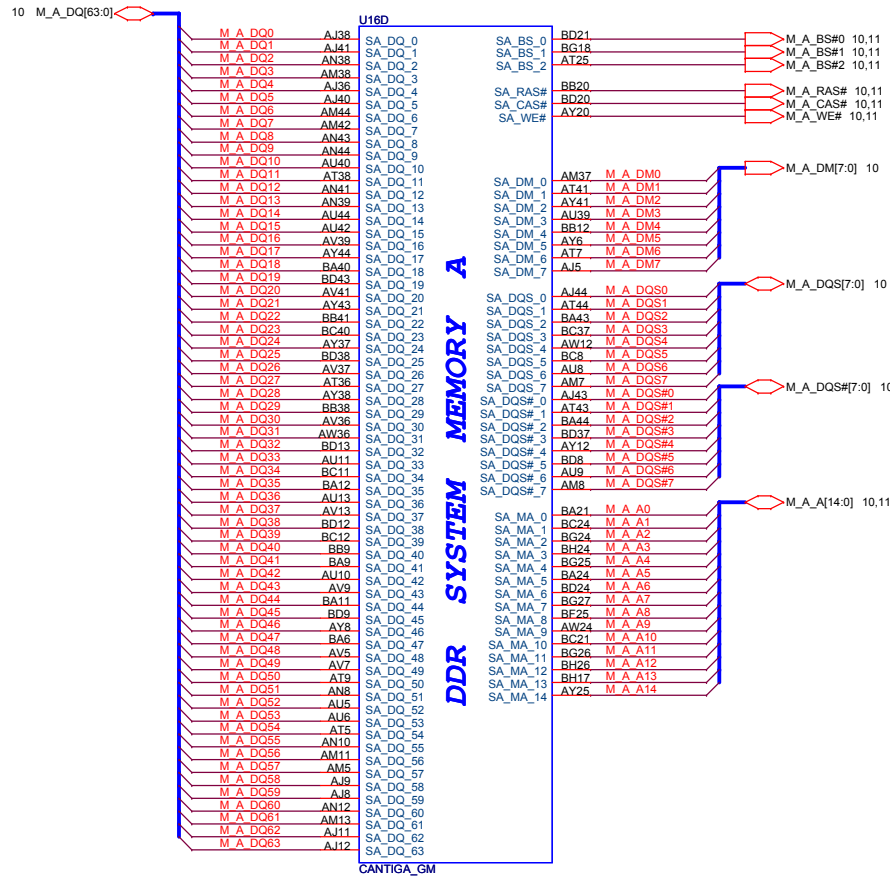

10/21 Montevina +1.8VSUS

2600mA

VCC\_SM\_36 through VCC\_SM\_42 can be left as NC for DDR2 designs.

VCC SM 36 BA36 VCC\_SM\_36/NC  
 VCC SM 37 BB24 VCC\_SM\_37/NC  
 VCC SM 38 BB16 VCC\_SM\_38/NC  
 VCC SM 40 AW16 VCC\_SM\_39/NC  
 VCC SM 42 AW13 VCC\_SM\_41/NC  
 AT13 VCC\_SM\_42/NC

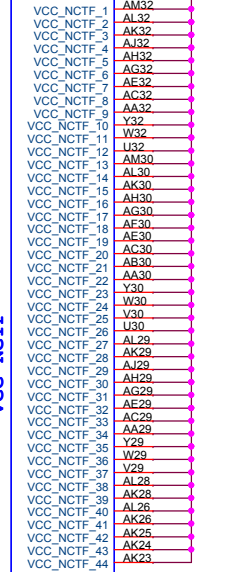
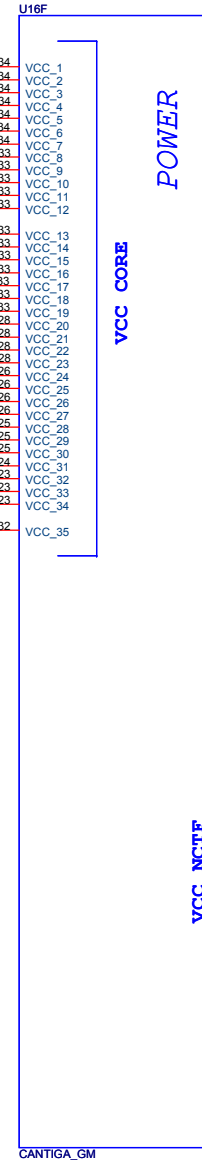
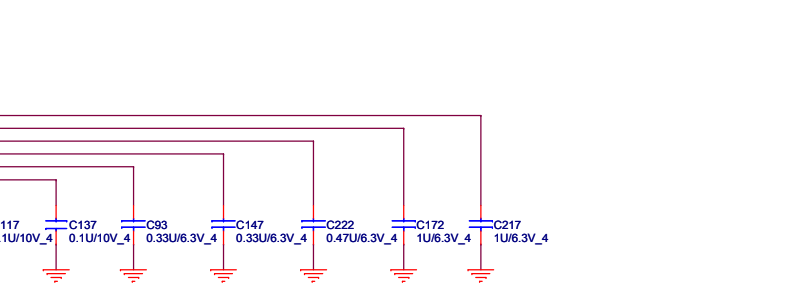
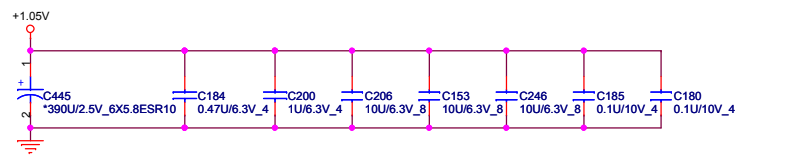
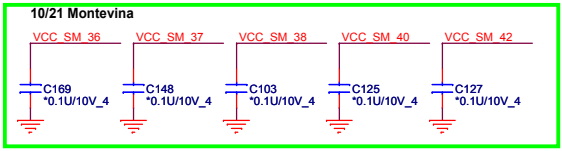
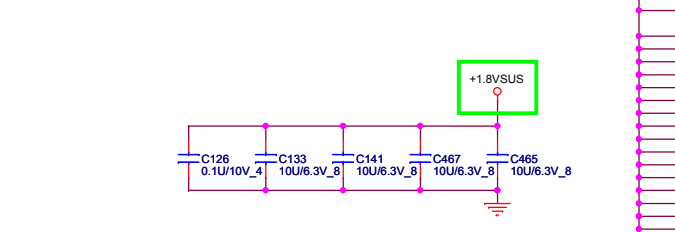
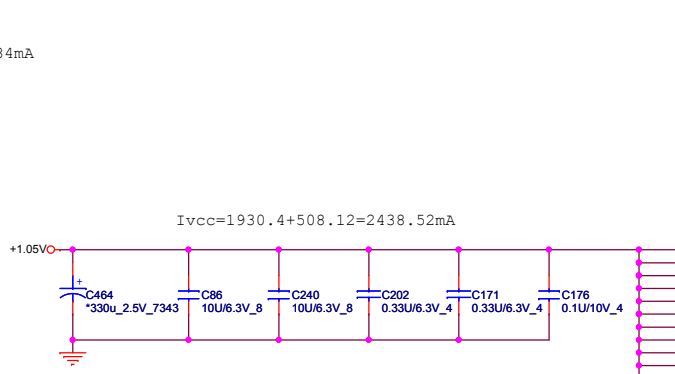
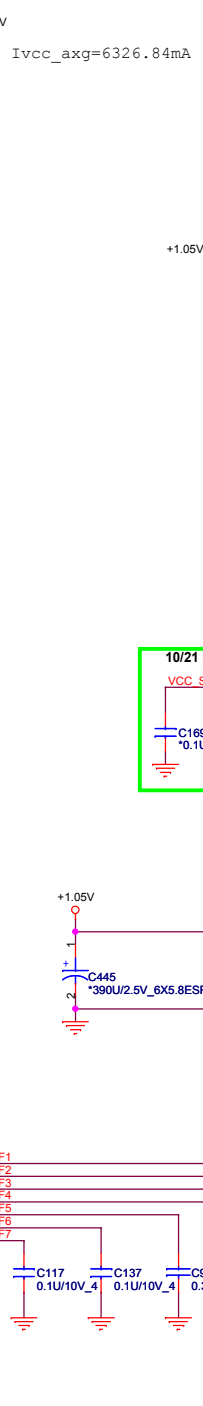
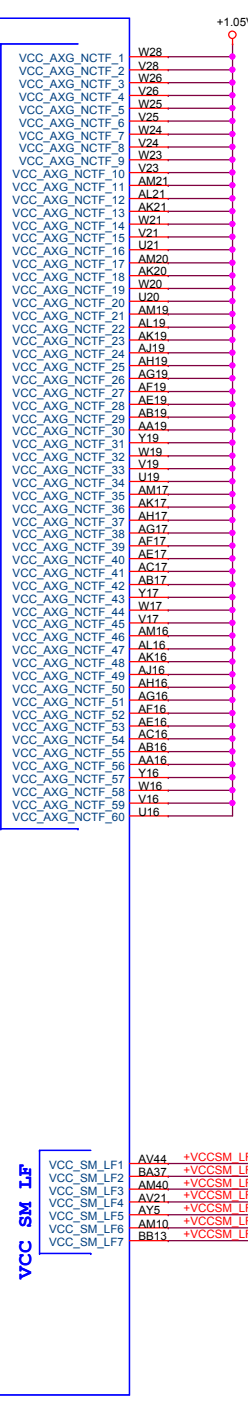
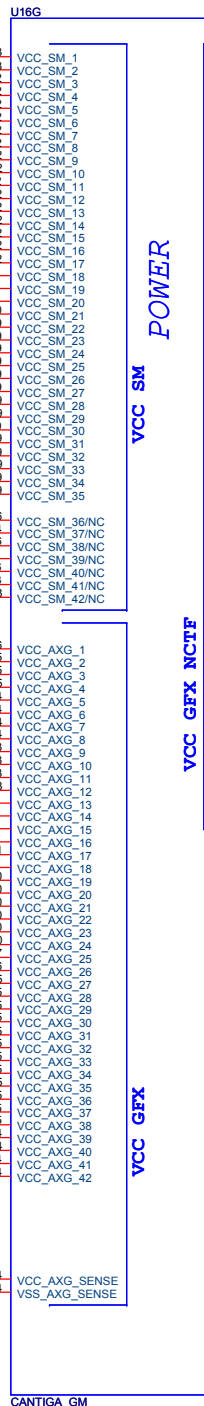

**PROJECT :AX3**  
 Quanta Computer Inc.

**NBS5**

Size Custom Document Number Cantiga VCC 4/5 Rev 2A

Date: Tuesday, February 23, 2010 Sheet 8 of 30



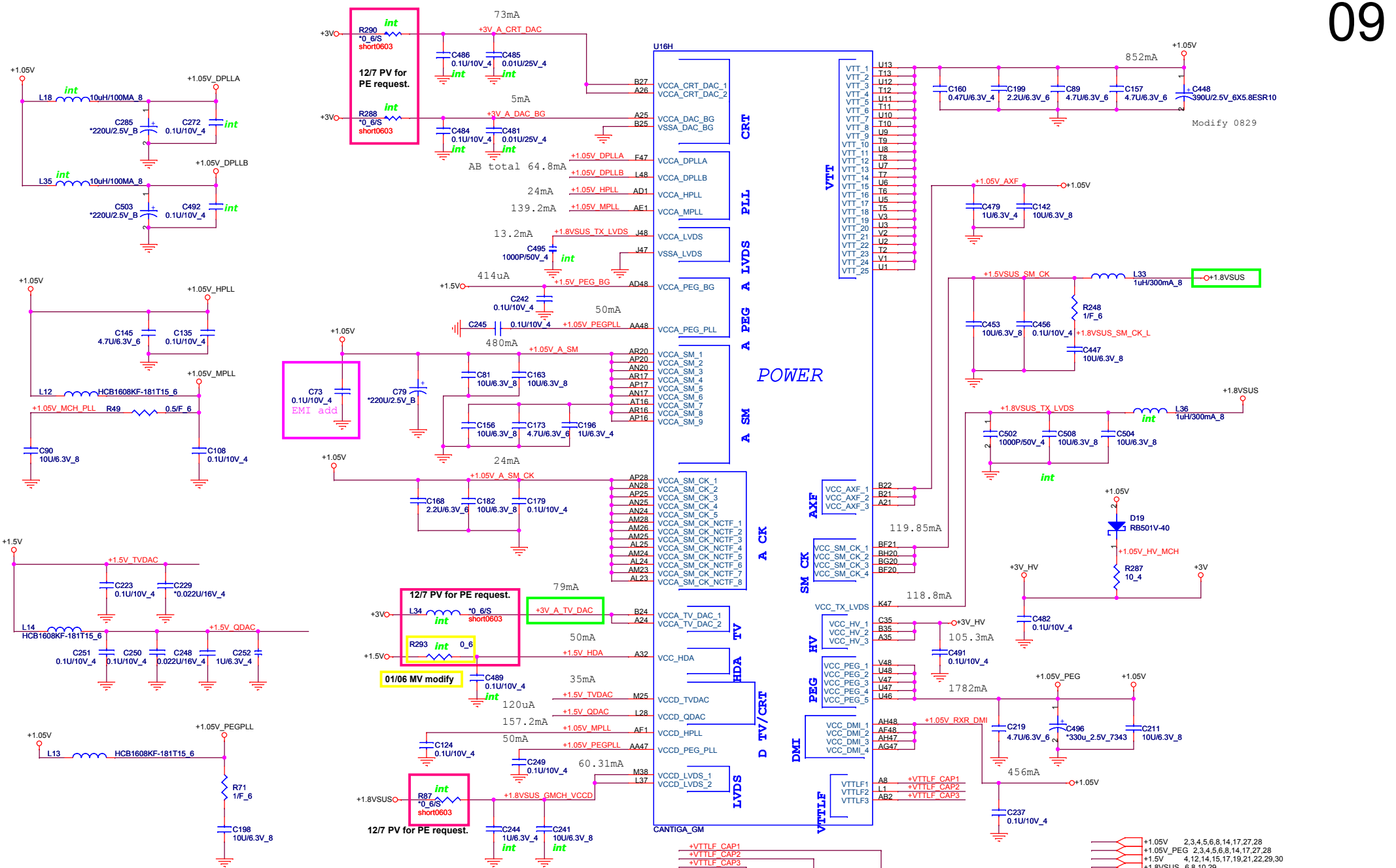

Modify to U40#AF1 power to +1.05V\_MPLL as CRB change

+1.05V	2,3,4,5,6,8,14,17,27,28
+1.05V_PEG	2,3,4,5,6,8,14,17,27,28
+1.5V	4, 12, 14, 15, 17, 19, 21, 22, 29, 30
+1.8VSUS	6, 8, 10, 29
+3V	2, 4, 6, 10, 12, 13, 14, 15, 16, 17, 18, 19, 20, 21, 22, 23, 24, 28, 30

**PROJECT :AX3**  
Quanta Computer Inc.

Size Custom	Document Number <b>Cantiga Power 5/5</b>	Rev 2A
Date: Tuesday, February 23, 2010 Sheet 9 of 30		

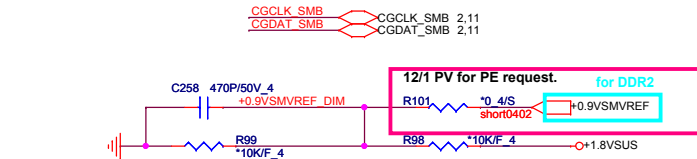
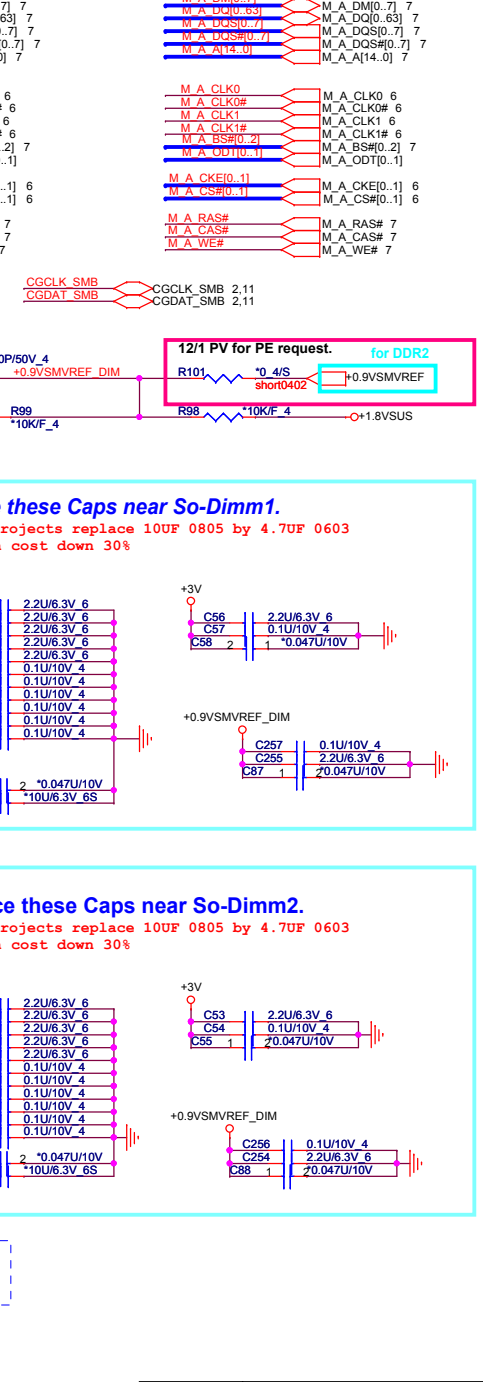
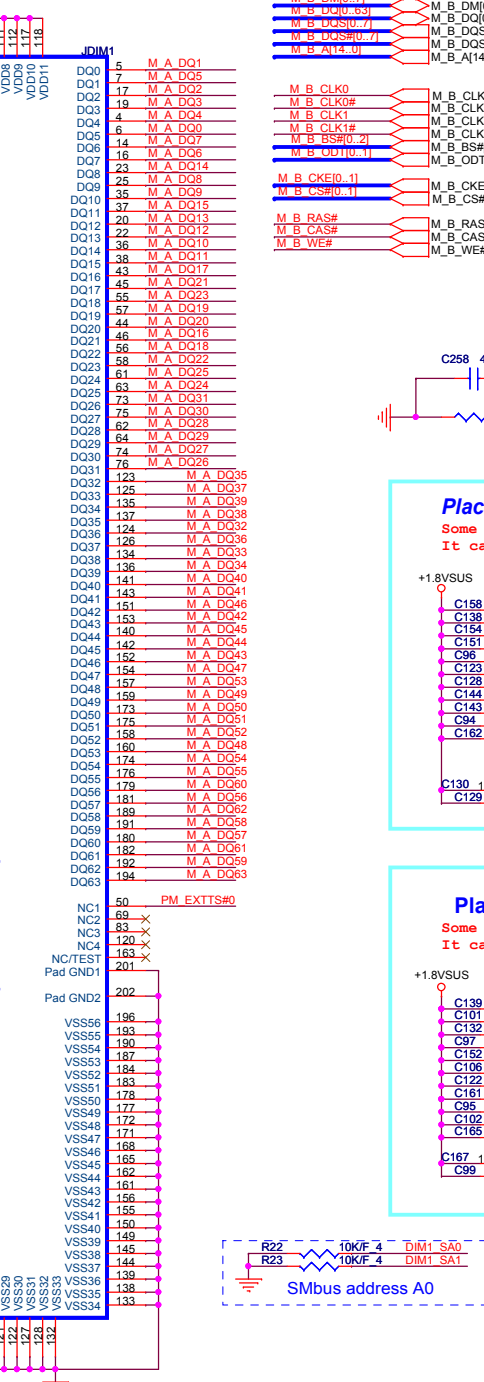
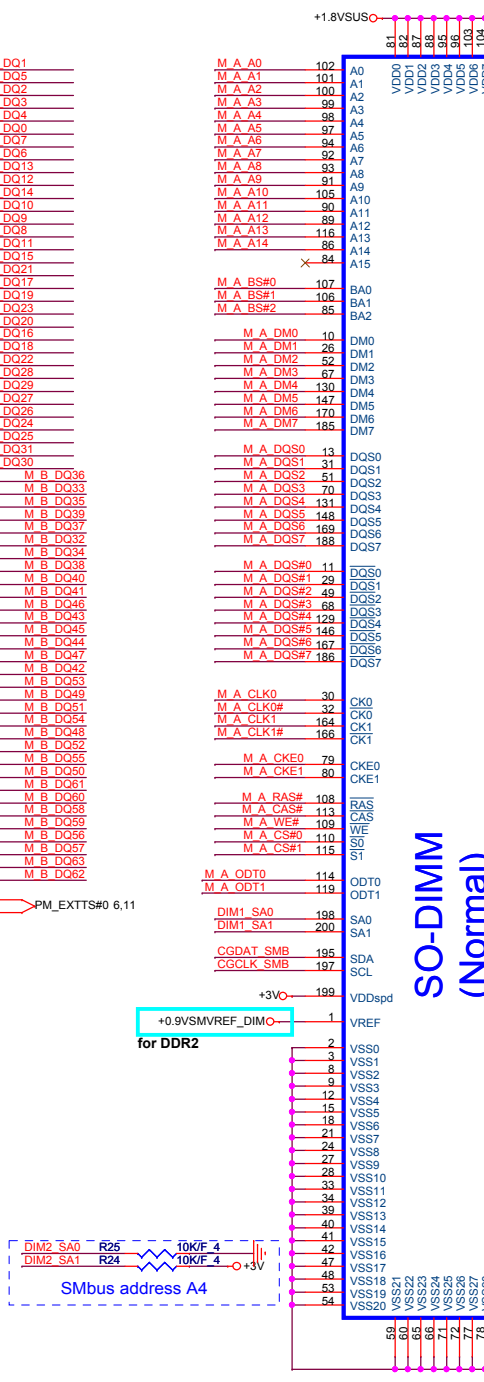
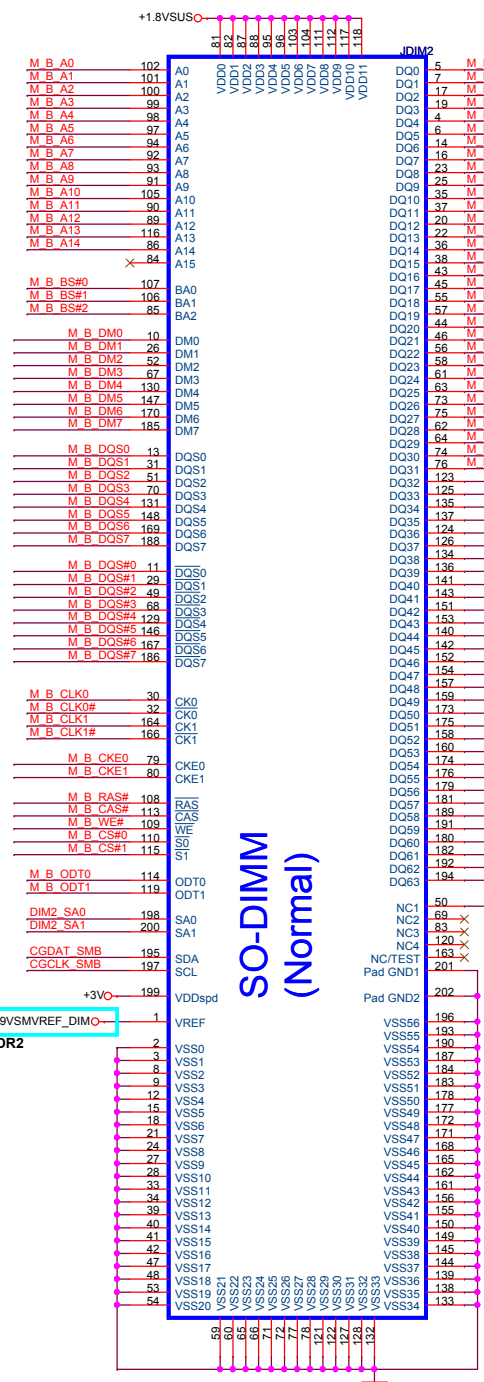

Place these Caps near So-Dimm1.  
Some Projects replace 10UF 0805 by 4.7UF 0603  
It can cost down 30%

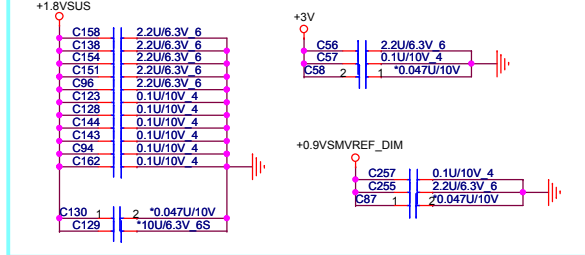

Place these Caps near So-Dimm2.  
Some Projects replace 10UF 0805 by 4.7UF 0603  
It can cost down 30%

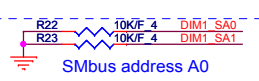
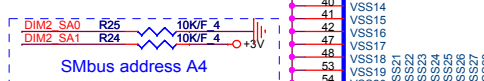
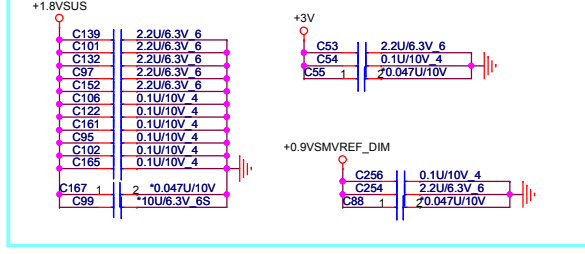

IC SOCKET DDR2 SO-DIMM(200P,H5.2,STD)  
DGMK000029  
DDR-1-1734075-1-200P

IC SOCKET DDR2 SO-DIMM(200P,H9.2,STD)  
DGMK000000  
DDR-1-1775859-1-200p-ldv

**PROJECT :AX3**  
Quanta Computer Inc.

Size Custom Document Number **DDR2 DIMM** Rev 2A

Date: Tuesday, February 23, 2010 Sheet 10 of 30

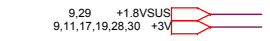

# DDRII DUAL CHANNEL A,B.

## DDRII A CHANNEL

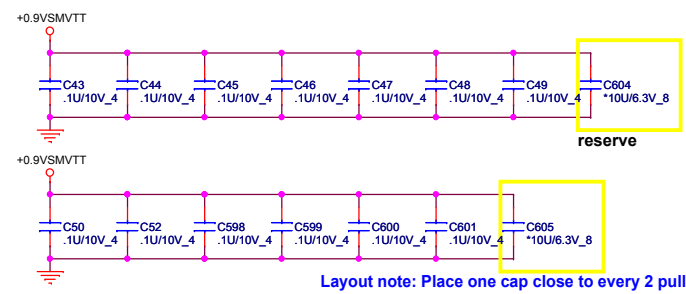

## DDRII B CHANNEL

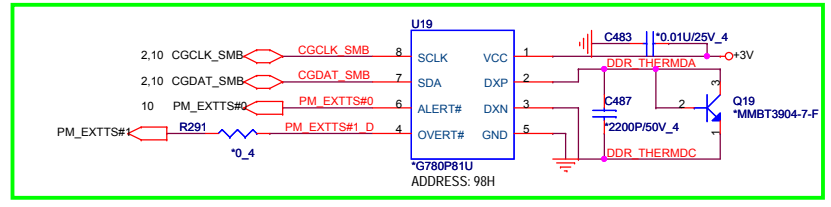
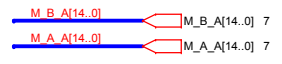
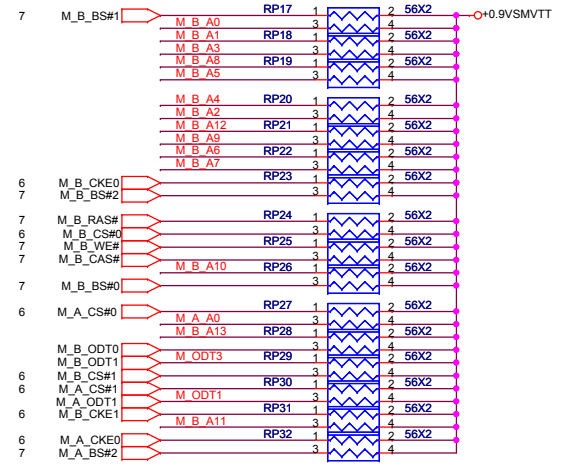
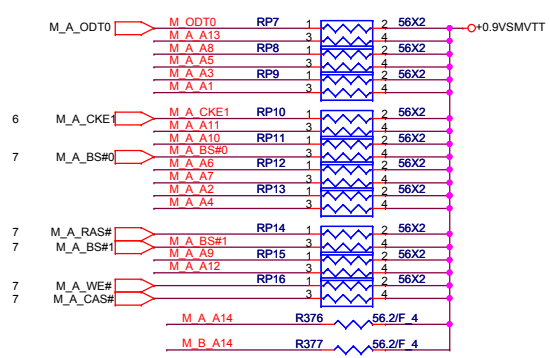
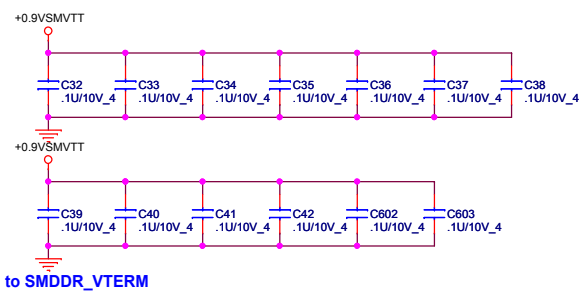

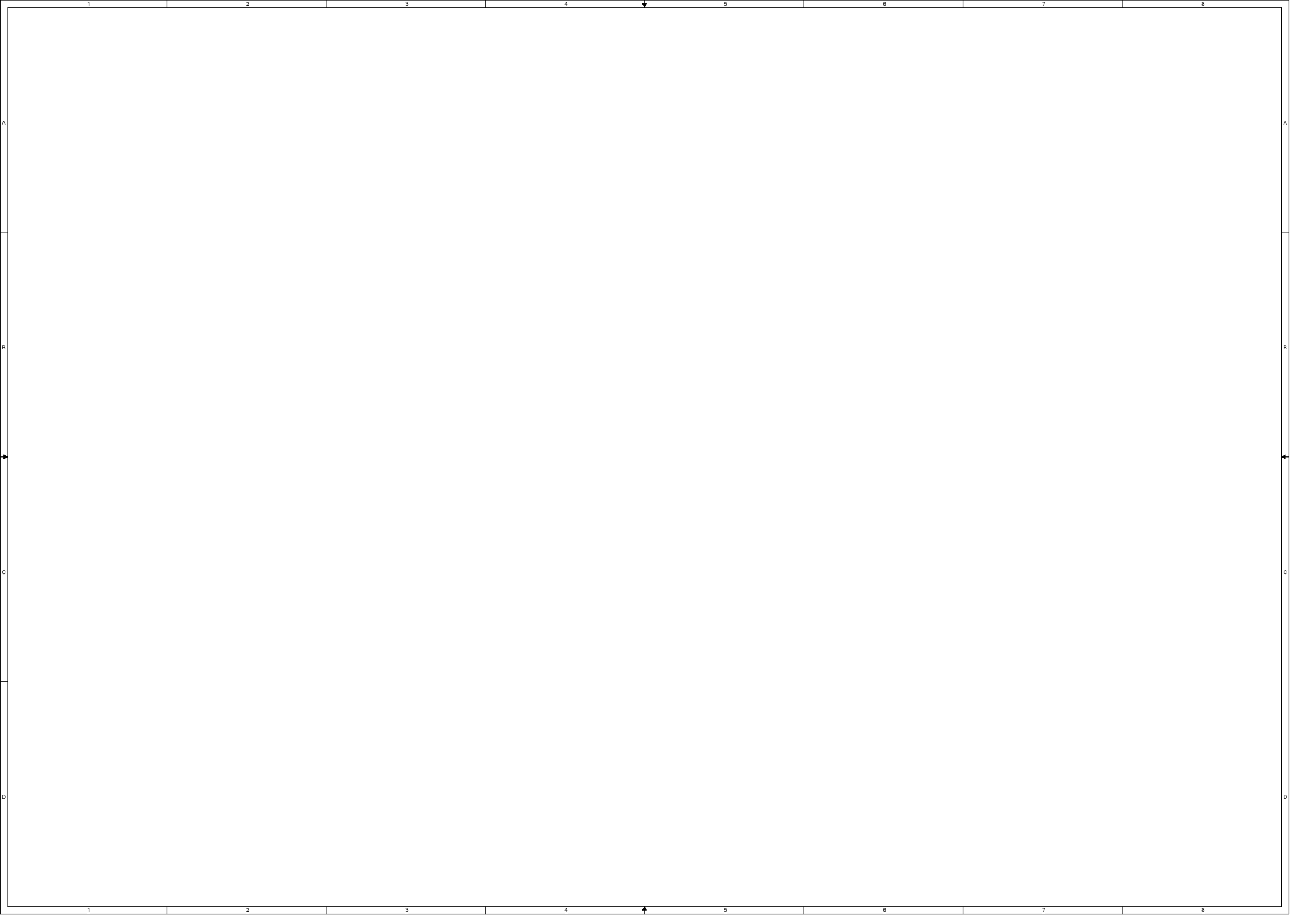

**CRT PORT**

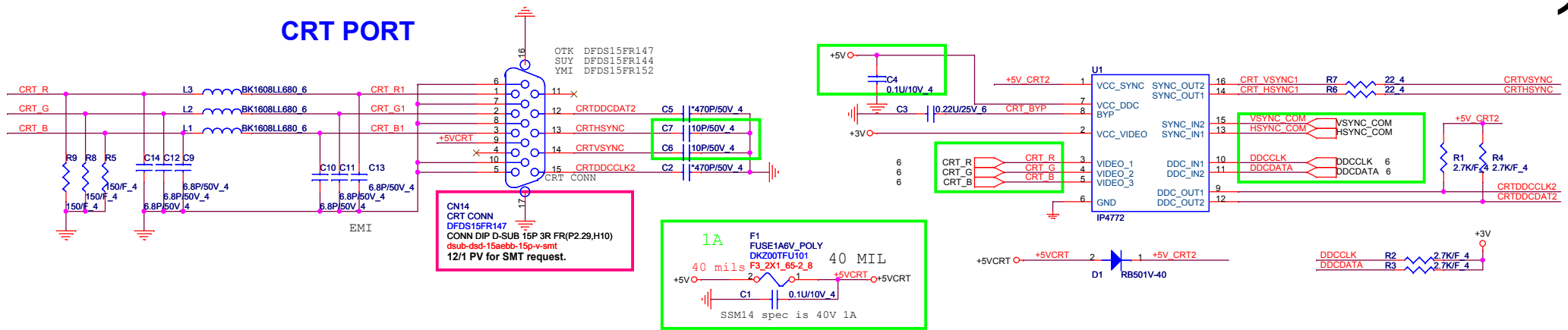

**For UMA HDMI function**

9/16 : PIM: need use ALP411LS000 or ALP411LS004 for capella  
CHR : need Na R1182, add R1027 for capella

Vendor:PDT P/N:AL008101001  
Vendor:CHR P/N:AL007318002  
Vendor:PIM P/N:ALP411LS002

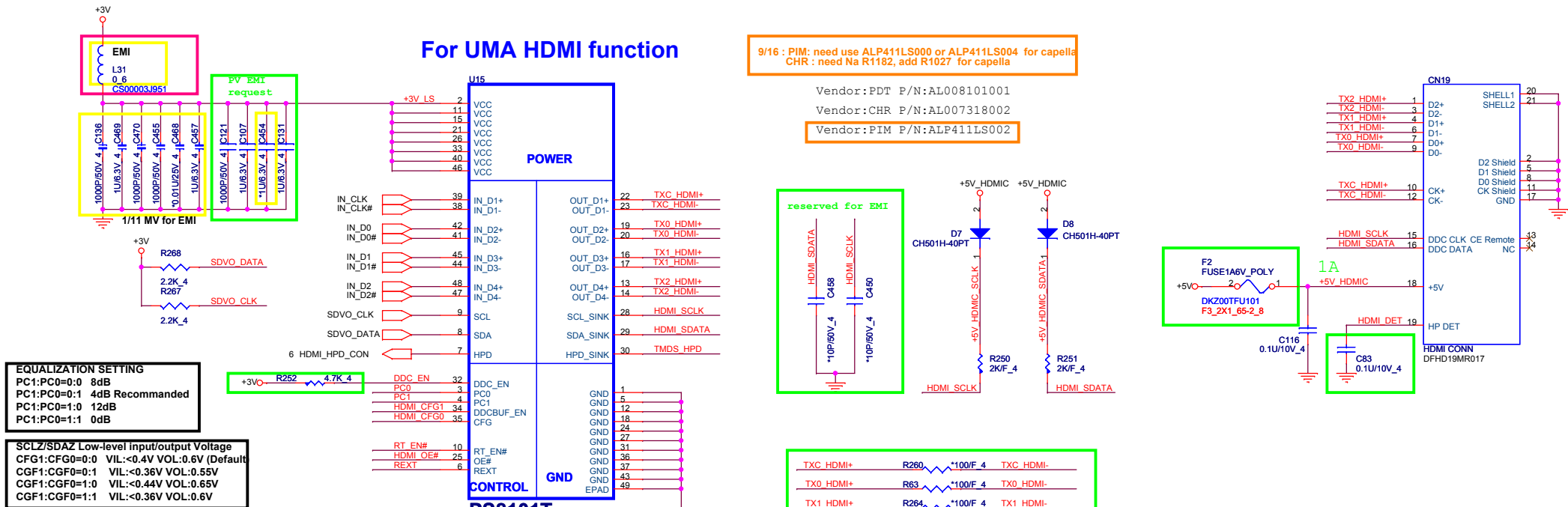

**EQUALIZATION SETTING**

PC1:PC0=0:0	8dB
PC1:PC0=0:1	4dB Recommended
PC1:PC0=1:0	12dB
PC1:PC0=1:1	0dB

**SCLZ/SDAZ Low-level input/output Voltage**

CFG1:CGF0=0:0	VIL:<0.4V VOL:0.6V (Default)
CGF1:CGF0=0:1	VIL:<0.36V VOL:0.55V
CGF1:CGF0=1:0	VIL:<0.44V VOL:0.65V
CGF1:CGF0=1:1	VIL:<0.36V VOL:0.6V

Signals	R	PDT	CHR	PIM
PC0	Ra	4.7K	NC	NC
	Rb	NC	NC	0
PC1	Rc	NC	10K	NC
	Rd	NC	NC	0
HDMI_CFG0	Re	NC	10K	NC
	Rf	NC	NC	0
	Rg	NC	10K	NC
	Rh	NC	NC	0
HDMI_CFG1	Ri	NC	NC	0
REXT	Rj	499	1.2K	0
RT_EN#	Rk	NC	NC	0
HDMI_OE#	Rl	NC	0	0

Detect	R	PDT	CHR	PIM
IC	Rm	0	20K	0
	Rn	NC	47K	NC
NB (Page6)	Da	NC	Stuff	NC
	Ro	NC	20K	20K
	Rp	NC	7.5K	7.5K
	Rq	0	0	0

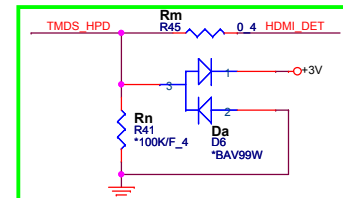



MINI CARD PCI-E (WLAN)

PCI-E-LAN

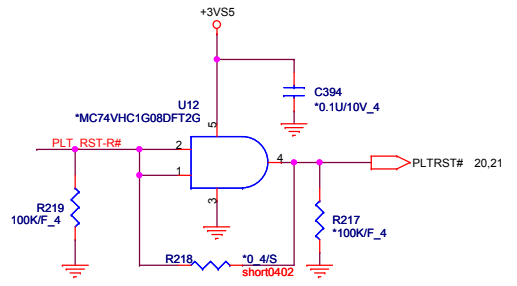
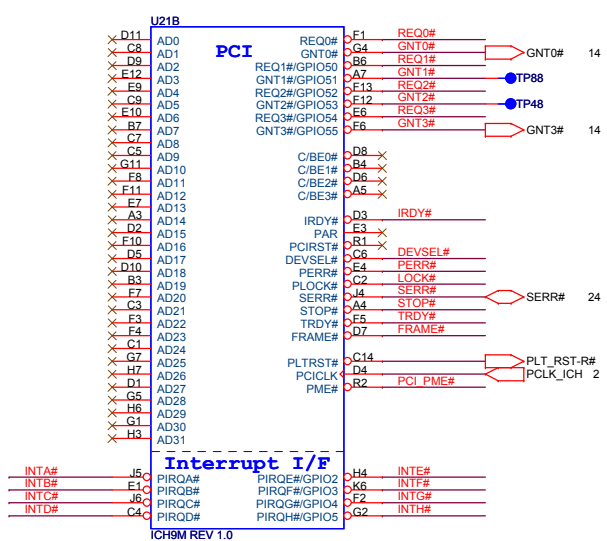
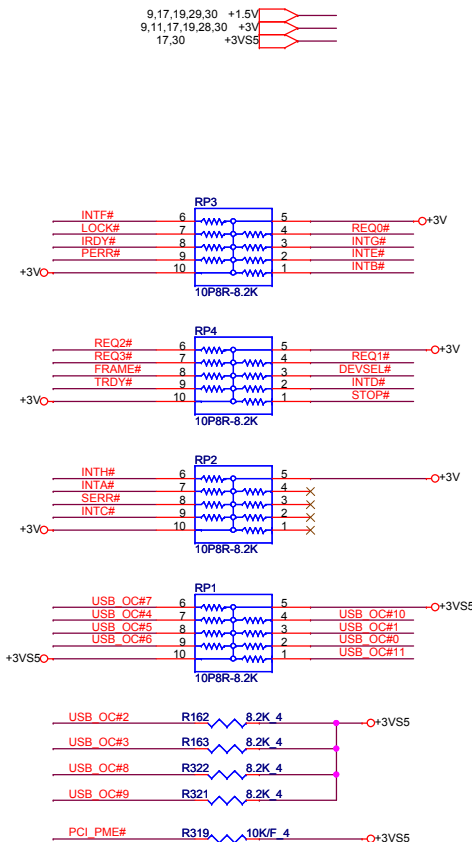
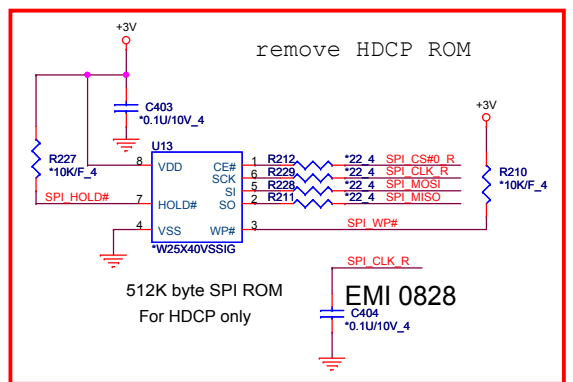
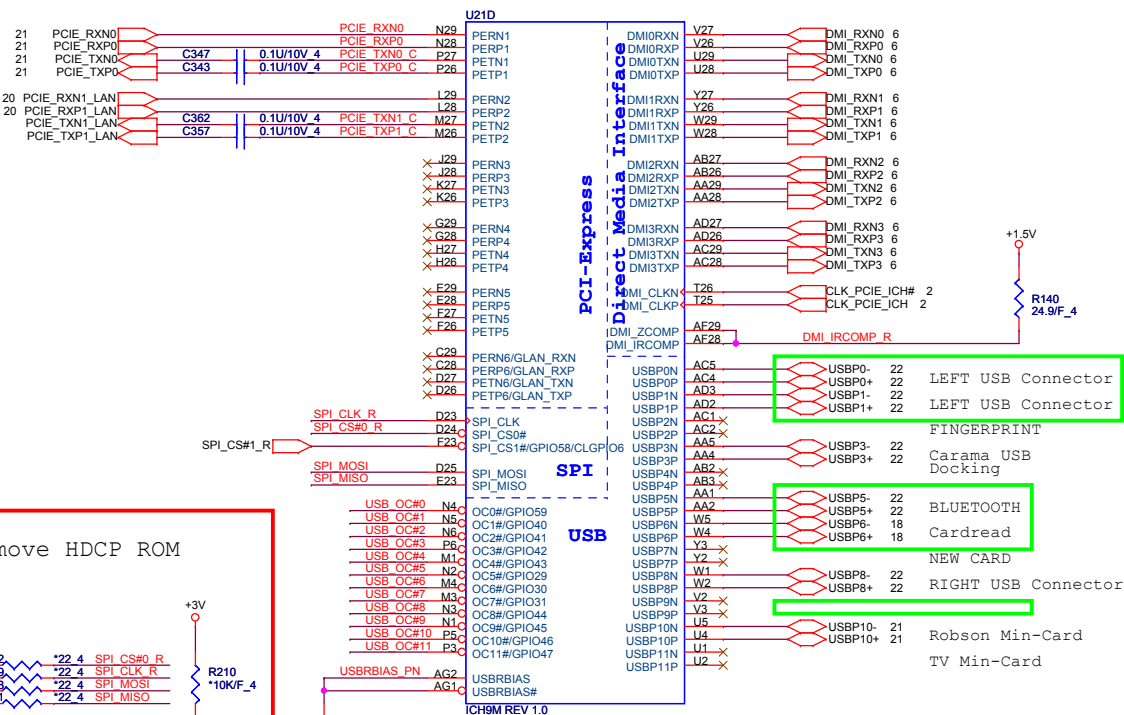

**PROJECT :AX3**  
Quanta Computer Inc.

**NBS5**

Size Custom Document Number **IC9M-M DMI/PCIe/USB 2/4** Rev 2A

Date: Tuesday, February 23, 2010 Sheet 15 of 30

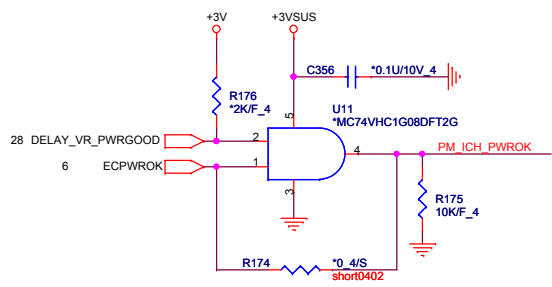
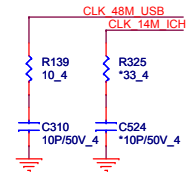
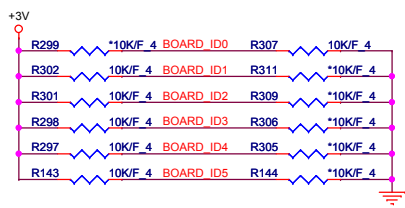
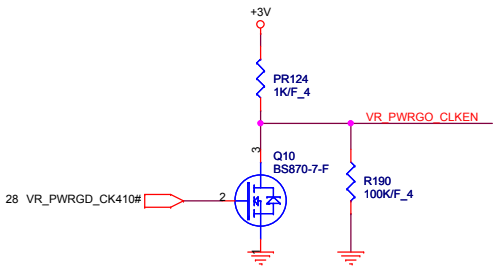
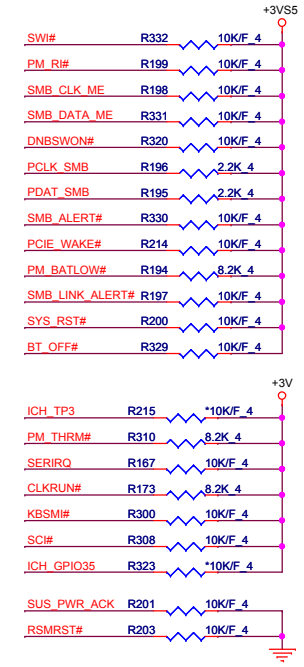
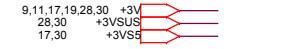
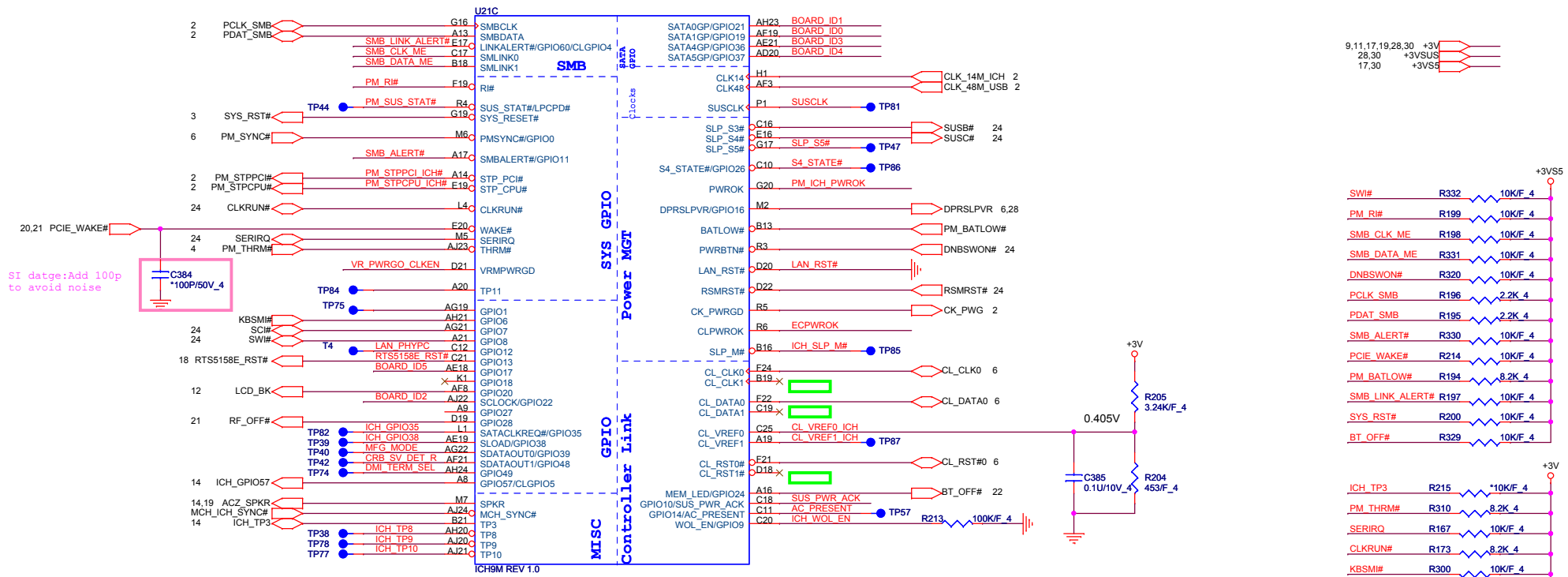

Board ID	ID0	ID1	ID2	ID3	ID4	ID5
	GPIO19	GPIO21	GPIO22	GPIO36	GPIO37	GPIO17
UMA/DIS	0=UMA 1=Dis.					
CR/HDMI		0=No 1=Yes				
Reserve			0=No 1=Yes			
Reserve				0=No 1=Yes		
Reserve					0=No 1=Yes	

AX3 MB P/N	ID0	ID1	ID2	ID3	ID4	ID5
31AX6MB0000 (CHR)	0	1	1	1	1	1
31AX6MB0010 (PD1)	0	1	1	1	1	1
31AX6MB0020 (PIM)	0	1	1	1	1	1
31AX6MB0030	0	0	1	1	1	1

**PROJECT :AX3**  
Quanta Computer Inc.

**NBS5**

Size Custom Document Number **IC99-M GPIO/Board ID 3/4** Rev 2A

Date: Tuesday, February 23, 2010 Sheet 16 of 30



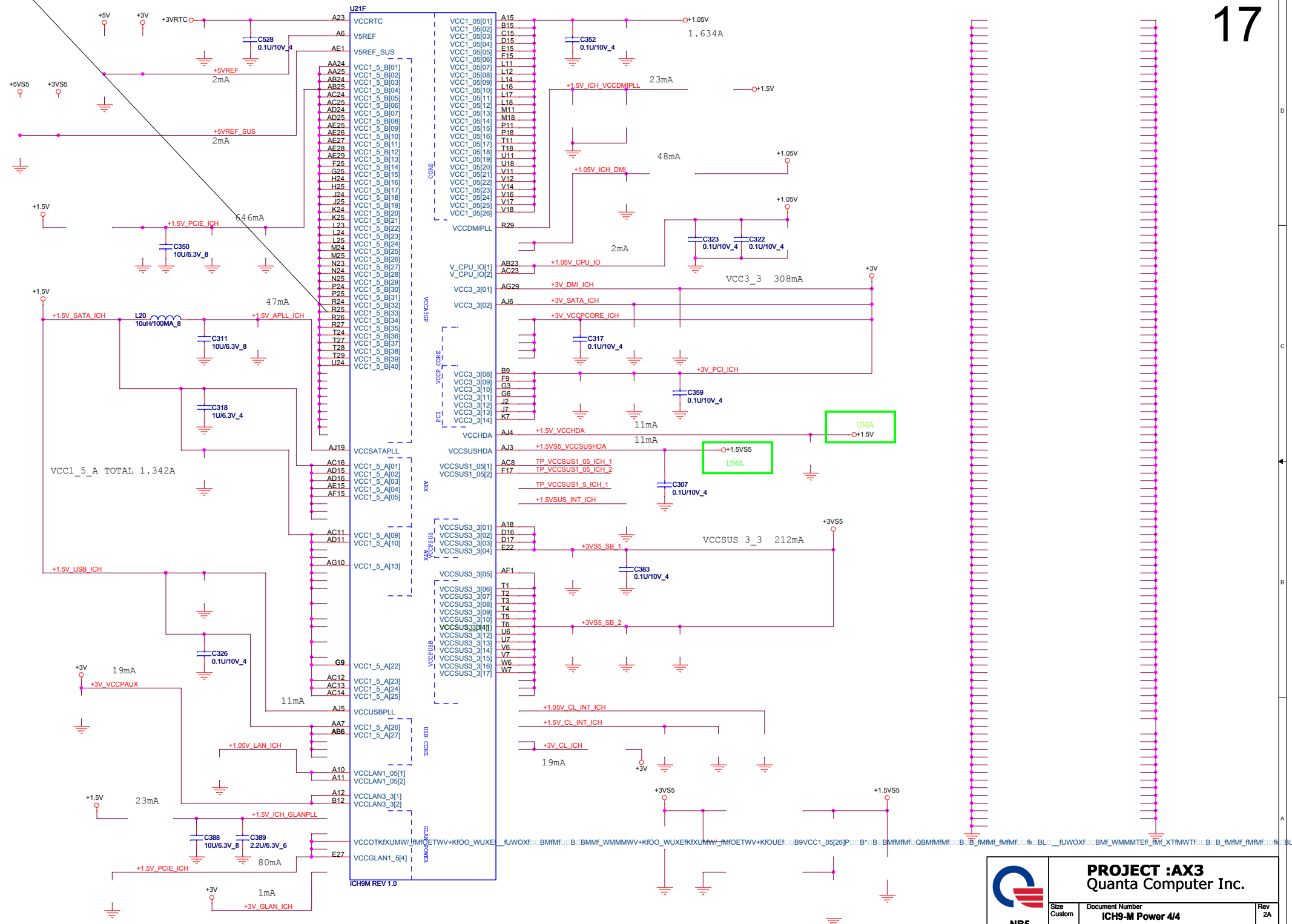

	<b>PROJECT :AX3</b>	
	Quanta Computer Inc.	
Size Custom	Document Number	Rev 2A
NB5	<b>ICH9-M Power 4/4</b>	
Date: Friday, January 29, 2010	Sheet 17 of 30	

PU for internal CLK input  
Unstuff for external XTAL(12MHZ)

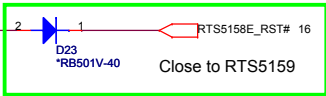
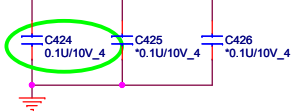
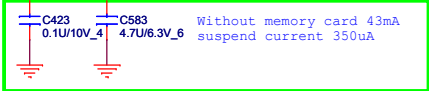
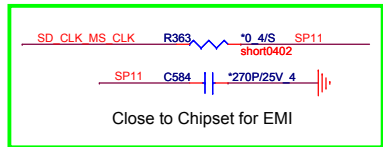
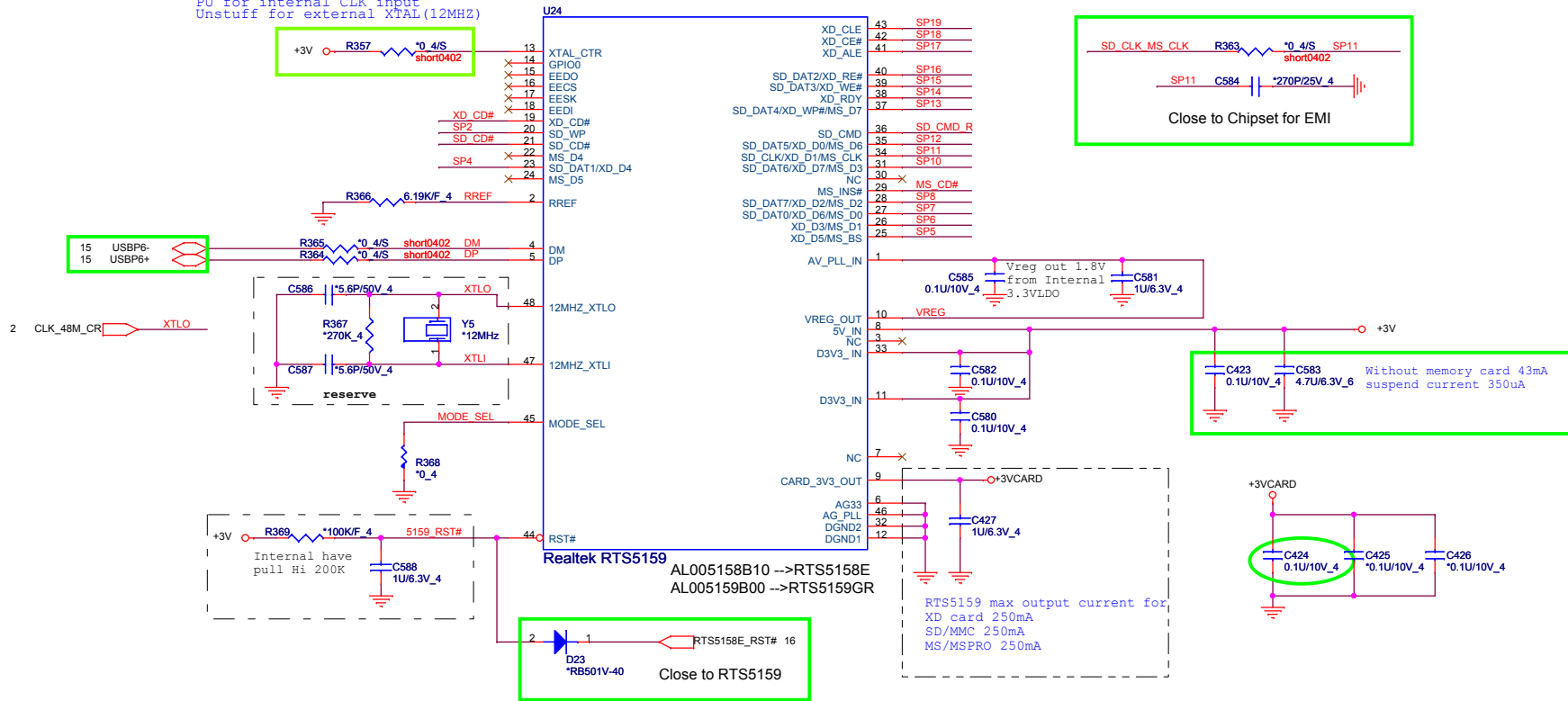

RTS5159 max output current for  
XD card 250mA  
SD/MMC 250mA  
MS/MSPRO 250mA

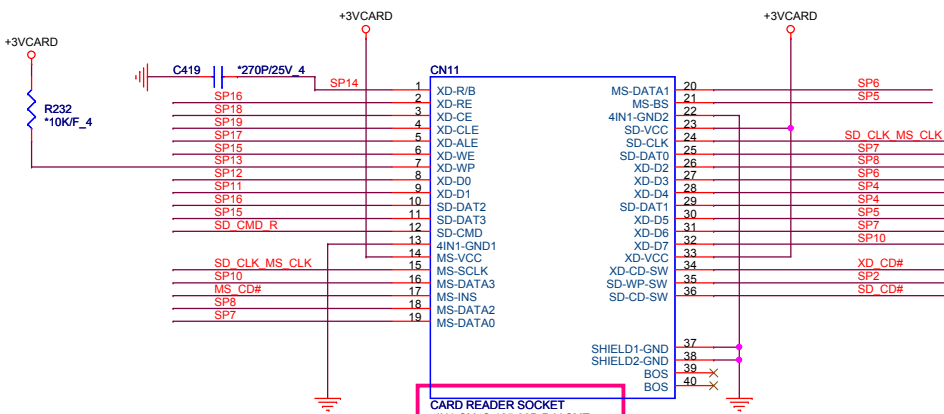

**5 IN1 CARD-READER (PUSH-PUSH)**  
Support SD/SD PRO/MMC/MS/MS PRO/xD Cards

CARD READER SOCKET  
4IN1-CM4S-12S-36P-R-V-SMT  
12/1 PV for SMT request.

**Note:**

SP0	SD/MMC	MS	XD
SP1	SD_WP		XD_CD#
SP2	SD_WP		XD_CD#
SP3	SD_CD#		
SP4	SD_DAT1		XD_D4
SP5		MS_BS	XD_D5
SP6		MS_D1	XD_D3
SP7	SD_DAT0	MS_D0	XD_D6
SP8	SD_DAT7	MS_D2	XD_D2
SP9		MS_INS#	
SP10	SD_DAT6	MS_D3	XD_D7
SP11	SD_CLK	MS_SCLK	XD_D1
SP12	SD_DAT5		XD_D0
SP13	SD_DAT4		XD_D1
SP14		XD_WP#	XD_R/#
SP15	SD_DAT3		XD_WE#
SP16	SD_DAT2		XD_RE#
SP17			XD_ALE
SP18			XD_CE#
SP19			XD_CLE

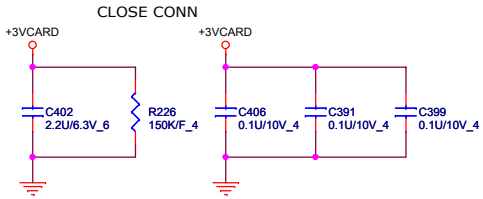

9,11,17,19,28,30 +3V

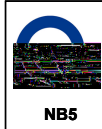

**PROJECT :AX3**  
Quanta Computer Inc.

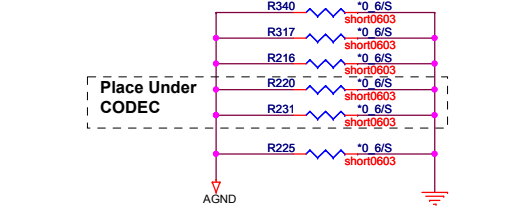
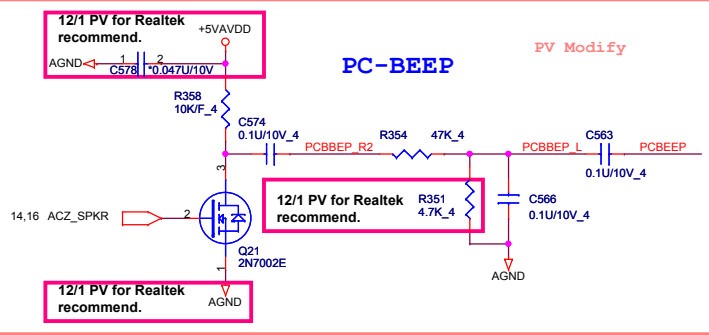
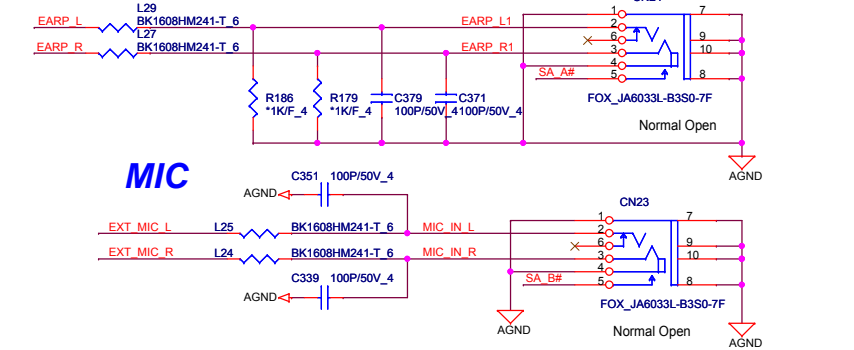
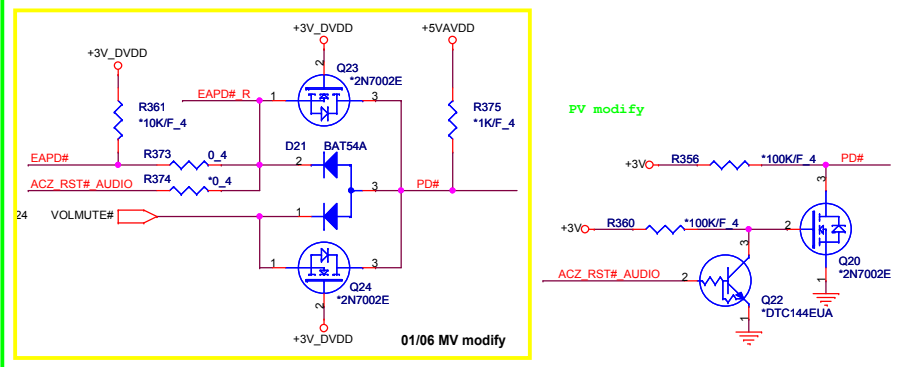
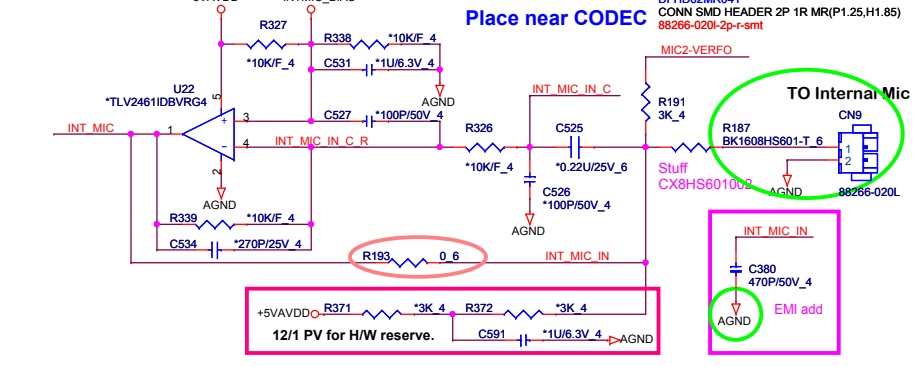
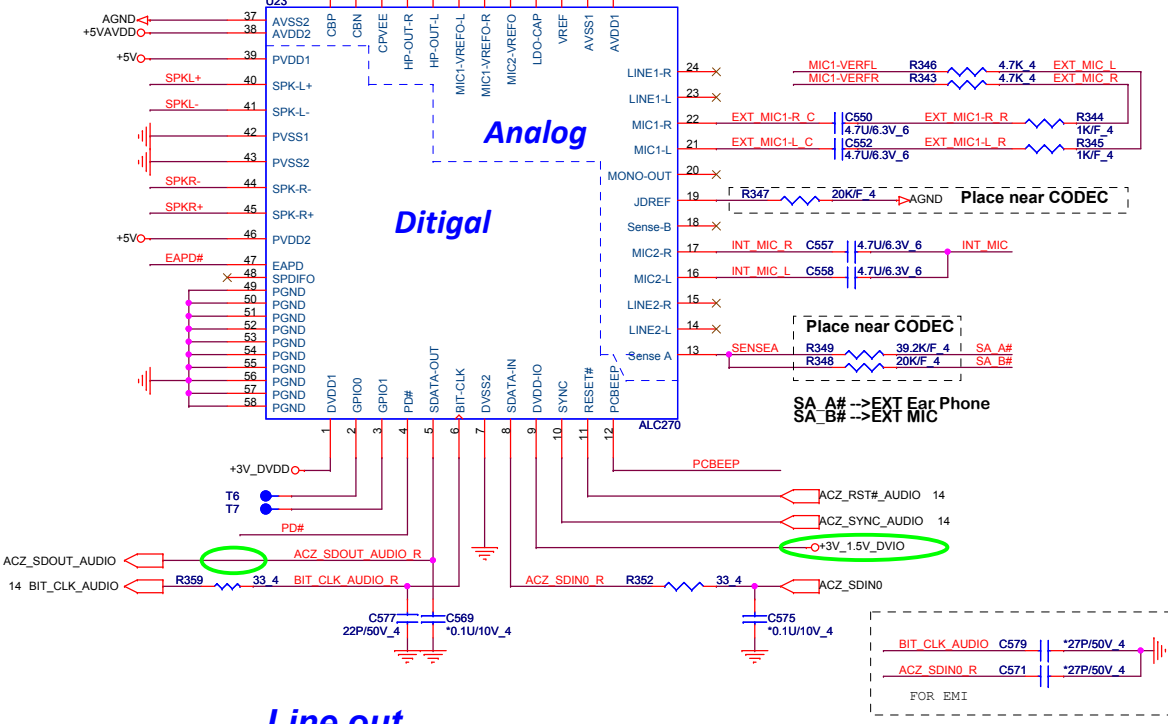
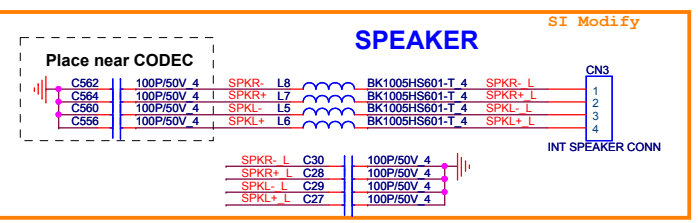
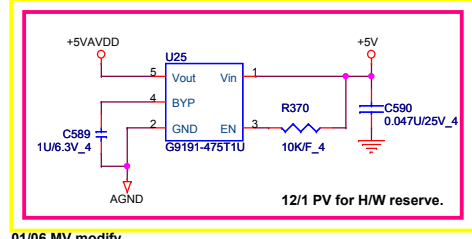
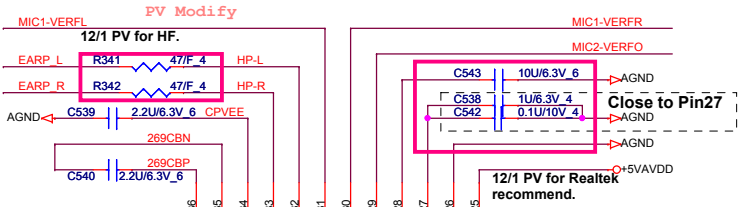
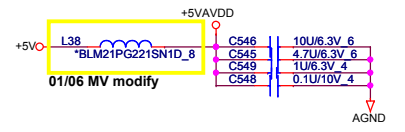
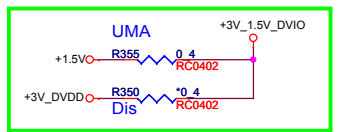
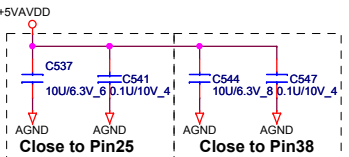
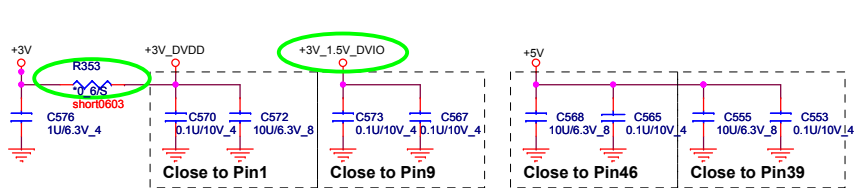

**PROJECT :AX3**  
Quanta Computer Inc.

Size Custom Document Number **Azalia ALC270/Audio Jack** Rev 1A

NBS Date: Tuesday, February 23, 2010 Sheet 19 of 30



### Mini PCI-E Card WLAN

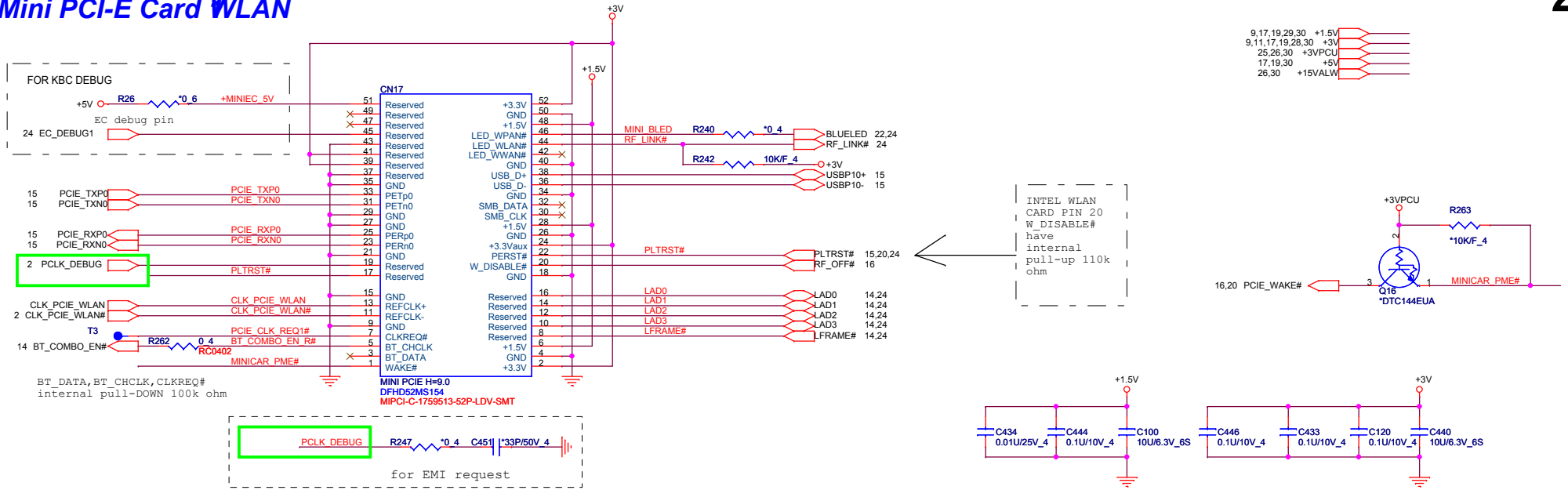

### SATA HDD CONNECTOR

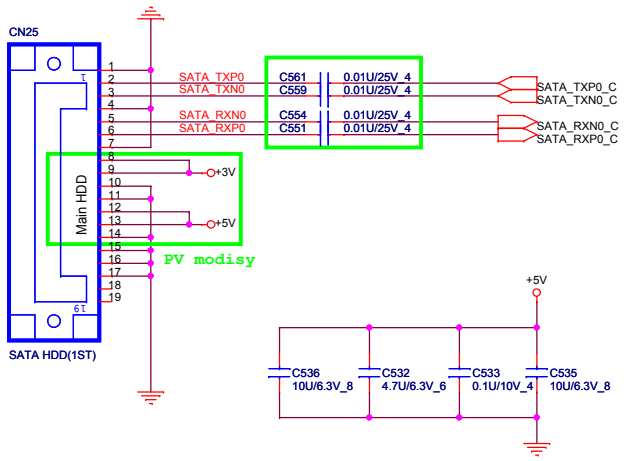

### SATA ODD CONNECTOR

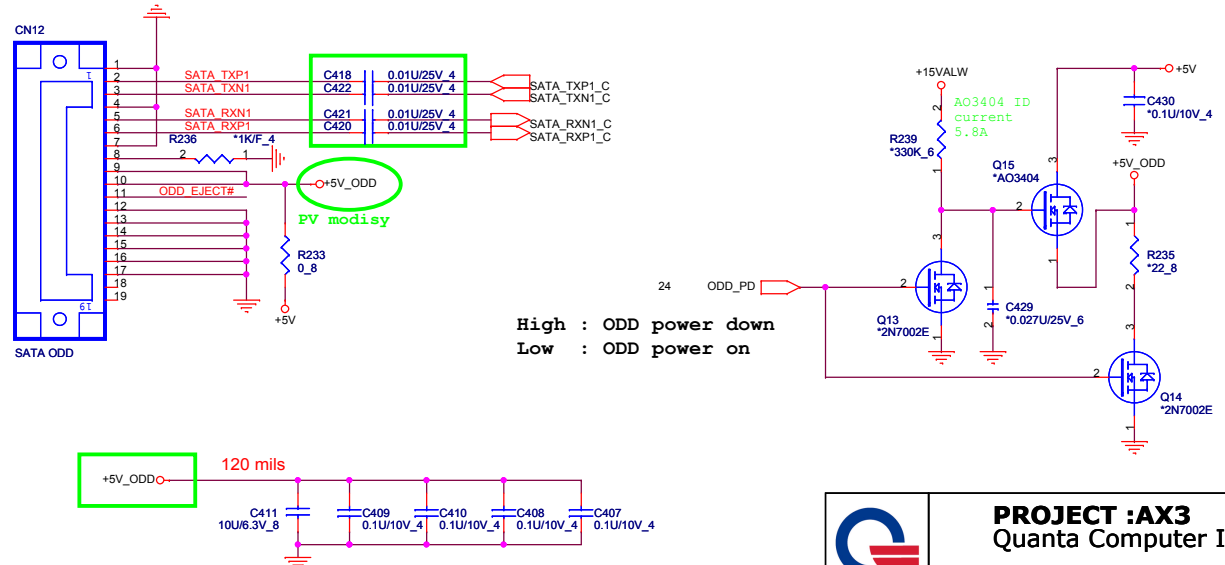





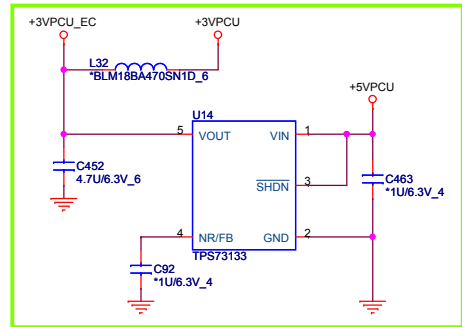
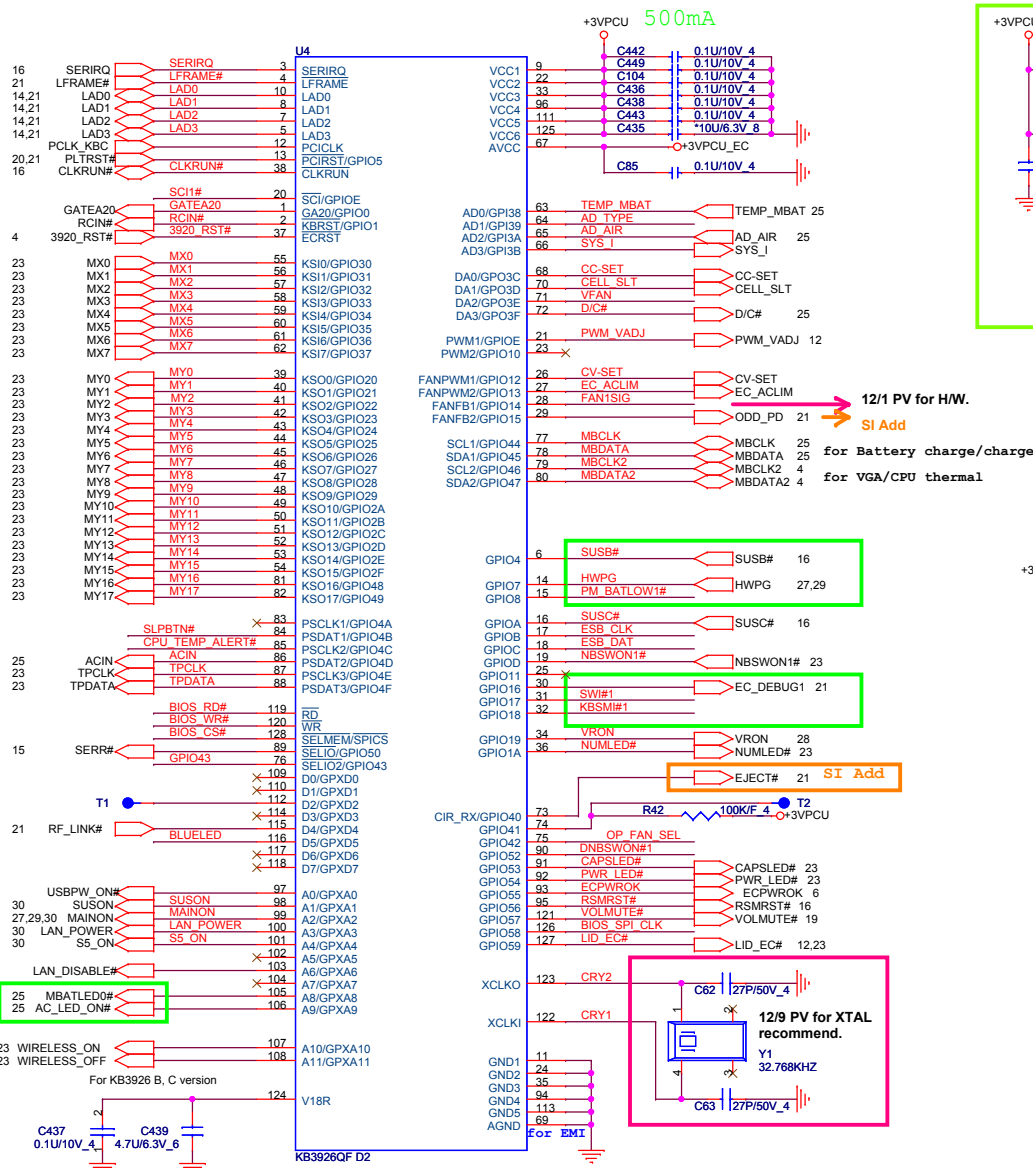

### CPU FAN

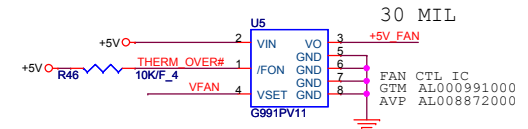

G995 layout notice

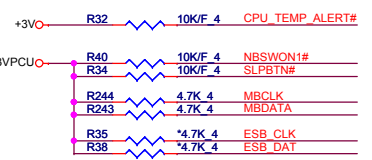

### Adapter select for EC

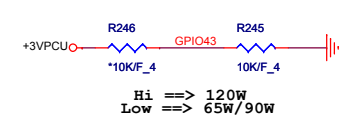

### 1M byte SPI EC ROM

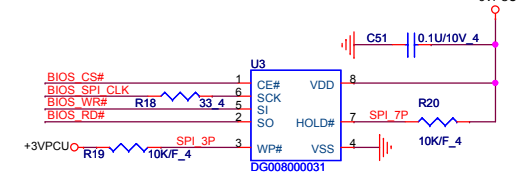

### GPIO42 control fan table

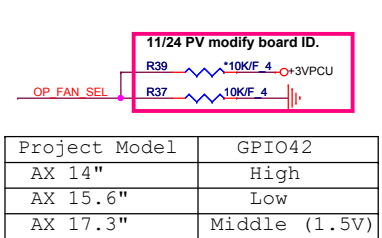

### adapter Type check

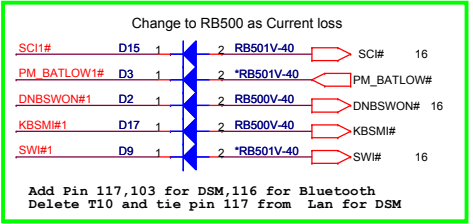
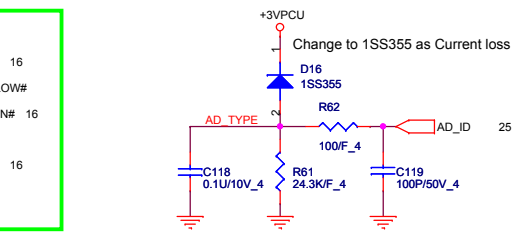

**PROJECT :AX3**  
Quanta Computer Inc.

Socket: DG008000031  
WINBOND AKE3GZN0N00  
EON AKE3GZP0Q00  
AIT AKE3GZP0801  
MAX AKE5GFK0Z09

8, 9, 11, 17, 19, 28, 30 +3V  
25, 26, 30 +3VPCU  
17, 19, 30 +5V  
25, 26, 27, 28, 29, 30 +5VPCU

**NBS5**

Size Custom Document Number **EC (KB3926)/ROM** Rev 2A

Date: Tuesday, February 23, 2010 Sheet 24 of 30



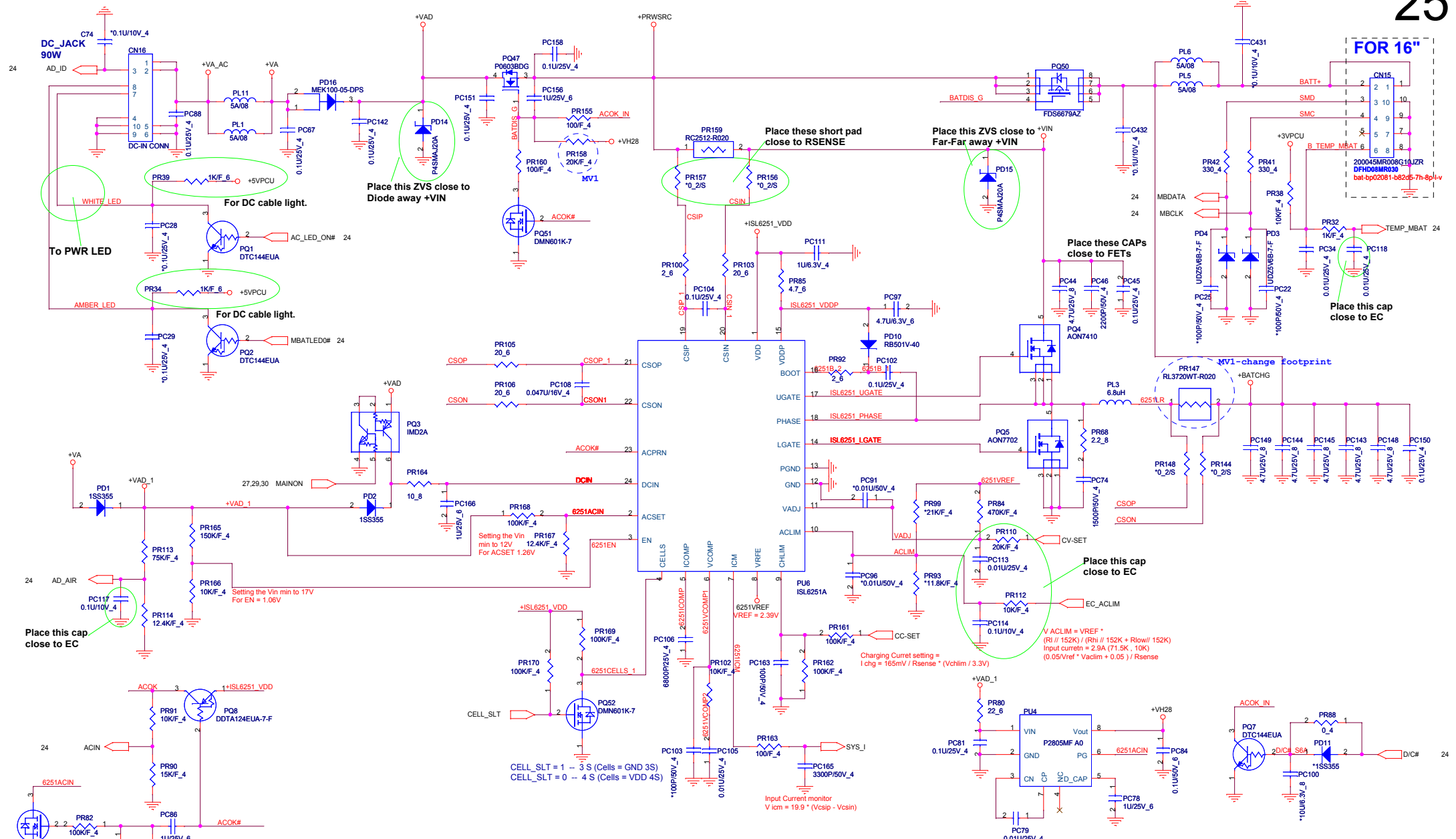

	<b>PROJECT :AX3</b>		Rev 2A
	Quanta Computer Inc.		
Size Custom	Document Number	CHARGER (ISL6251)	
Date: Tuesday, February 23, 2010   Sheet 25 of 30			

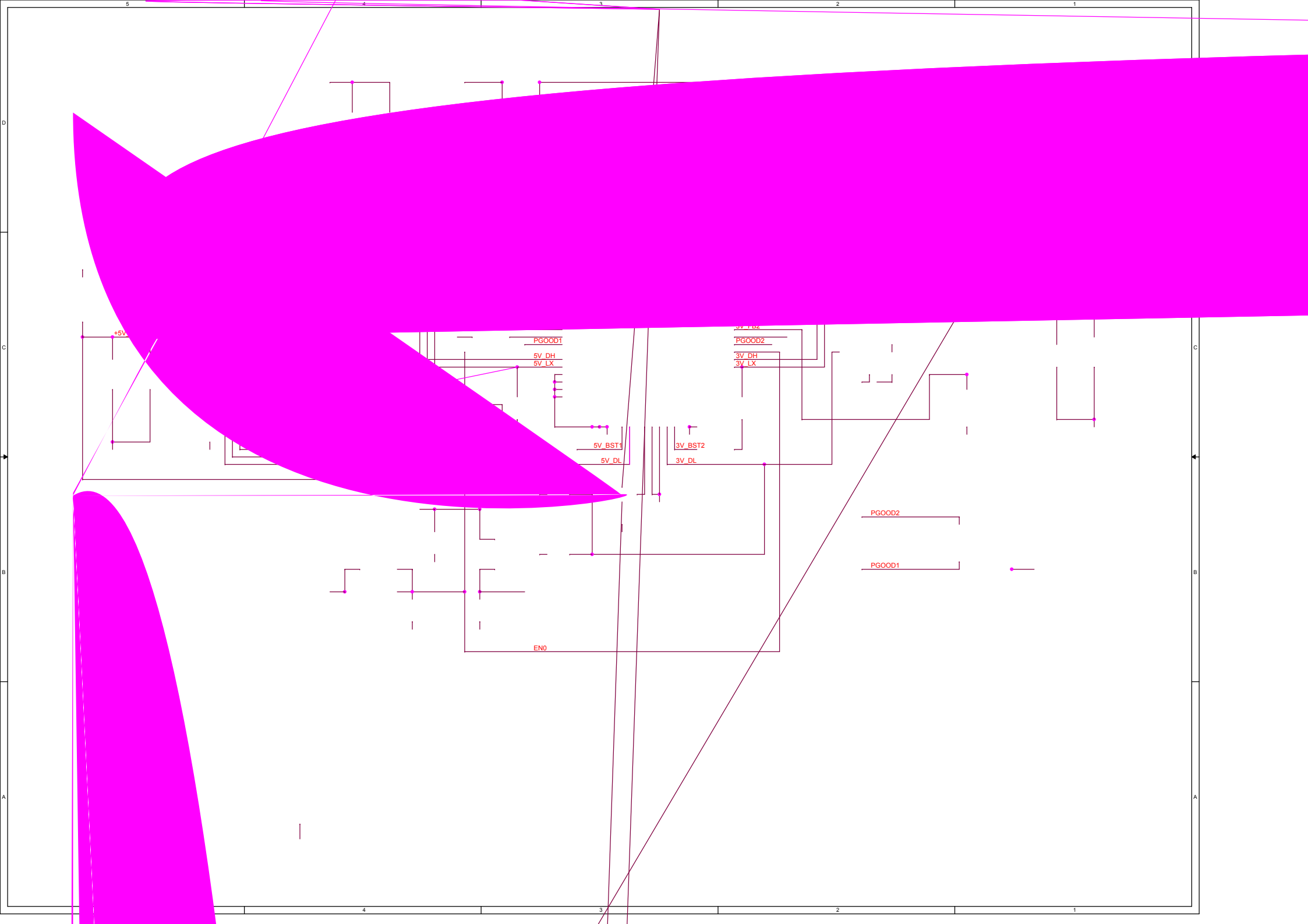

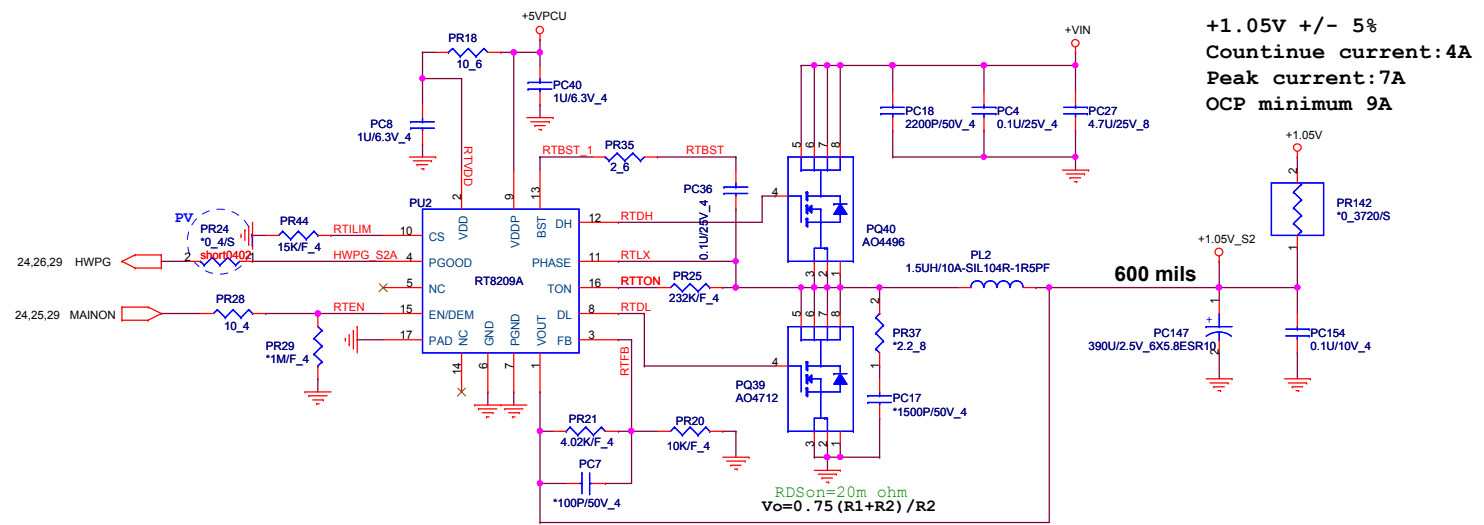

**PROJECT :AX3**  
**Quanta Computer Inc.**

Size Custom	Document Number <b>+1.05V</b>	Rev 2A
Date: Tuesday, February 23, 2010		Sheet 27 of 30

Merom: VCC\_CORE/ 44A  
Yonah: VCC\_CORE/ 36A

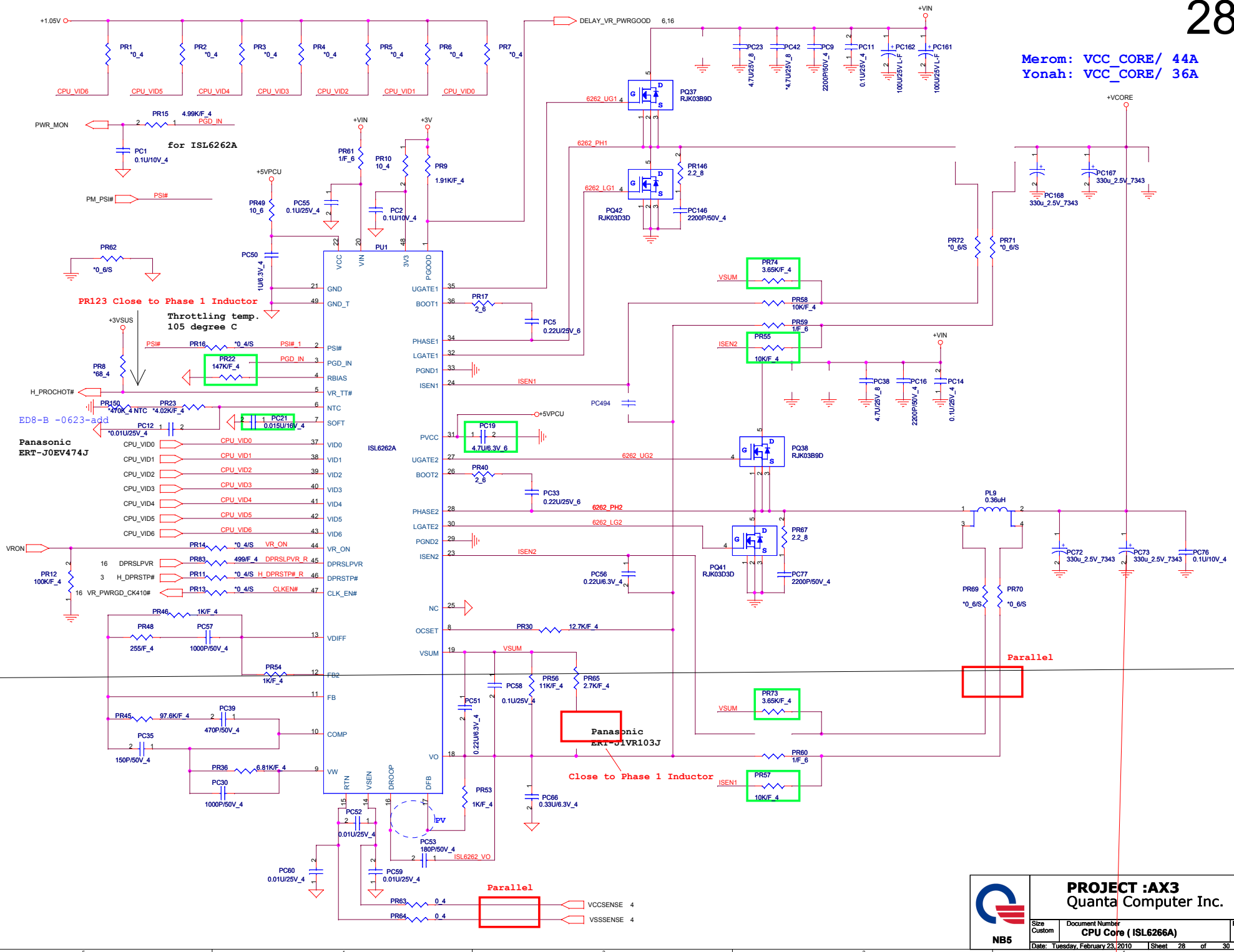

	<b>PROJECT :AX3</b>	
	Quanta Computer Inc.	
Size Custom	Document Number	Rev 2A
CPU Core ( ISL6266A)		
Date: Tuesday, February 23, 2010   Sheet 28 of 30		

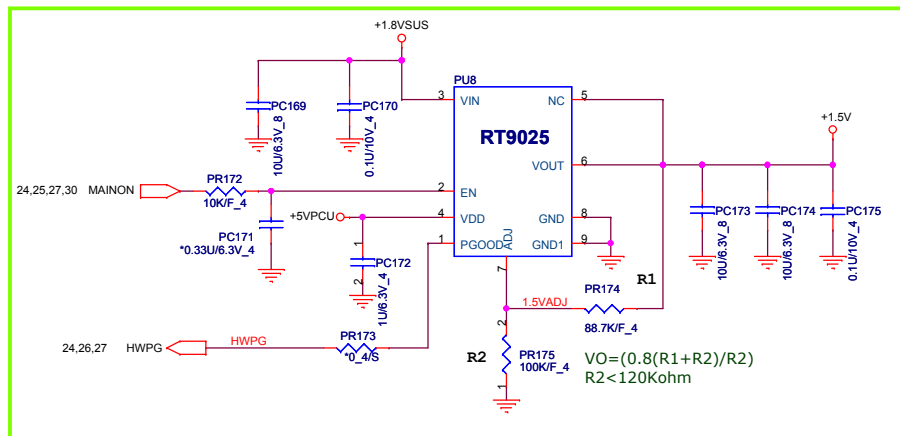
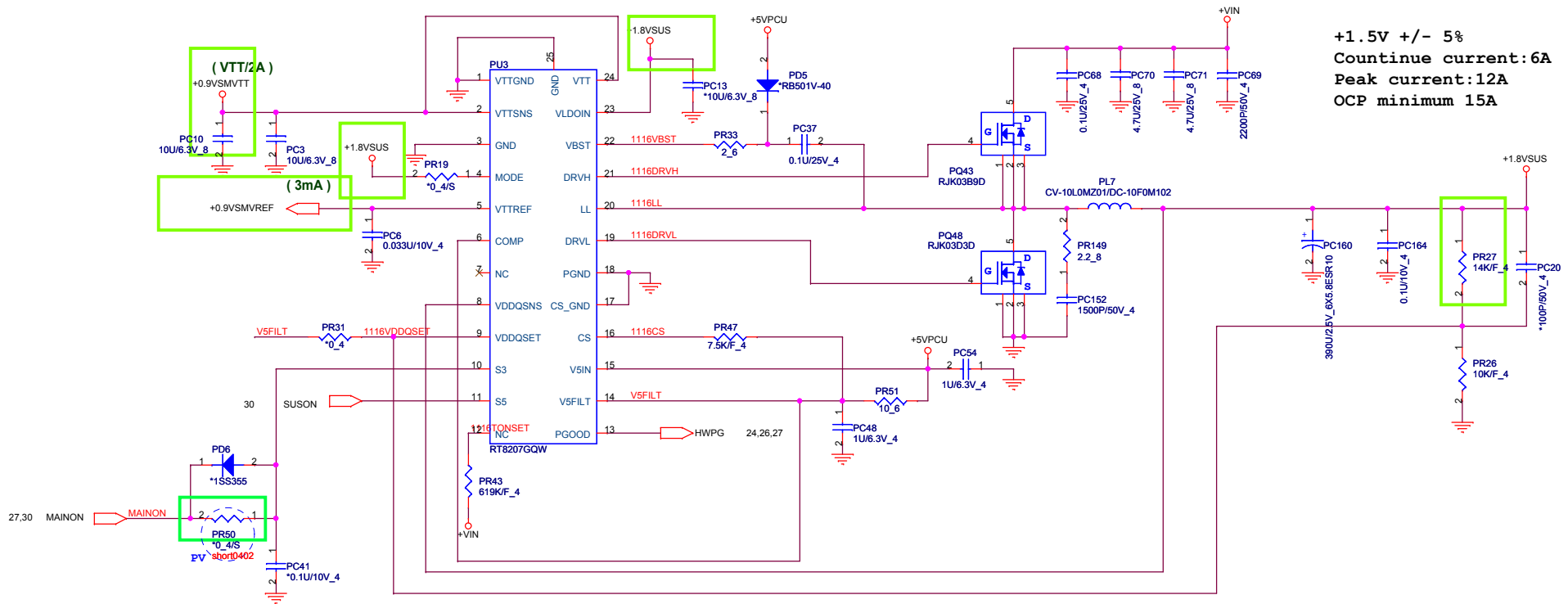

**PROJECT :AX3**  
**Quanta Computer Inc.**

Size Custom	Document Number <b>DDR3 (RT8207)</b>	Rev 2A
Date: Tuesday, February 23, 2010 Sheet 29 of 30		

